



60EPU06  
60APU06

## Ultrafast Soft Recovery Diode

### Features

- Ultrafast Recovery
- 175°C Operating Junction Temperature

### Benefits

- Reduced RFI and EMI
- Higher Frequency Operation
- Reduced Snubbing
- Reduced Parts Count

$$t_{rr} = 34\text{ns (typ)}$$

$$I_{F(AV)} = 60\text{Amp}$$

$$V_R = 600\text{V}$$

### Description/ Applications


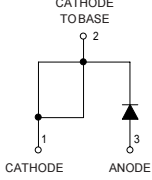

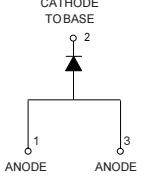
These diodes are optimized to reduce losses and EMI/ RFI in high frequency power conditioning systems. The softness of the recovery eliminates the need for a snubber in most applications. These devices are ideally suited for HF welding, power converters and other applications where switching losses are not significant portion of the total losses.

### Absolute Maximum Ratings

| Parameters  | Max         | Units            |
|---|-------------|------------------|
| $V_R$ Cathode to Anode Voltage                                    | 600         | V                |
| $I_{F(AV)}$ Continuous Forward Current, $T_C = 116^\circ\text{C}$ | 60          | A                |
| $I_{FSM}$ Single Pulse Forward Current, $T_C = 25^\circ\text{C}$  | 600         |                  |
| $I_{FRM}$ ① Maximum Repetitive Forward Current                    | 120         |                  |
| $T_J, T_{STG}$ Operating Junction and Storage Temperatures        | - 55 to 175 | $^\circ\text{C}$ |

① Square Wave, 20kHz

### Case Styles

|   |  |
|---|--|
| <p><b>60EPU06</b></p>   <p><b>TO-247AC (Modified)</b></p> | <p><b>60APU06</b></p>   <p><b>TO-247AC</b></p> |
|---|--|

**Electrical Characteristics @ T<sub>J</sub> = 25°C (unless otherwise specified)**

| Parameters   | Min | Typ  | Max  | Units | Test Conditions   |
|--|-----|------|------|-------|---|
| V <sub>BR</sub> , V <sub>r</sub> Breakdown Voltage, Blocking Voltage | 600 | -    | -    | V     | I <sub>R</sub> = 100μA  |
| V <sub>F</sub> Forward Voltage                                       | -   | 1.35 | 1.68 | V     | I <sub>F</sub> = 60A  |
|  | -   | 1.20 | 1.42 | V     | I <sub>F</sub> = 60A, T <sub>J</sub> = 125°C                  |
|  | -   | 1.11 | 1.30 | V     | I <sub>F</sub> = 60A, T <sub>J</sub> = 175°C                  |
| I <sub>R</sub> Reverse Leakage Current                               | -   | -    | 50   | μA    | V <sub>R</sub> = V <sub>R</sub> Rated                         |
|  | -   | -    | 500  | μA    | T <sub>J</sub> = 150°C, V <sub>R</sub> = V <sub>R</sub> Rated |
| C <sub>T</sub> Junction Capacitance                                  | -   | 39   | -    | pF    | V <sub>R</sub> = 600V   |

**Dynamic Recovery Characteristics @ T<sub>J</sub> = 25°C (unless otherwise specified)**

| Parameters                              | Min | Typ  | Max | Units | Test Conditions  |                        |
|---|-----|------|-----|-------|--|------------------------|
| t <sub>rr</sub> Reverse Recovery Time   | -   | 34   | 45  | ns    | I <sub>F</sub> = 1A, di <sub>F</sub> /dt = 200A/μs, V <sub>R</sub> = 30V<br><br>I <sub>F</sub> = 60A<br>V <sub>R</sub> = 200V<br>di <sub>F</sub> /dt = 200A/μs |                        |
|   | -   | 81   | -   |       |  | T <sub>J</sub> = 25°C  |
|   | -   | 164  | -   |       |  | T <sub>J</sub> = 125°C |
| I <sub>RRM</sub> Peak Recovery Current  | -   | 7.4  | -   | A     | T <sub>J</sub> = 25°C  |                        |
|   | -   | 17.0 | -   |       | T <sub>J</sub> = 125°C   |                        |
| Q <sub>rr</sub> Reverse Recovery Charge | -   | 300  | -   | nC    | T <sub>J</sub> = 25°C  |                        |
|   | -   | 1394 | -   |       | T <sub>J</sub> = 125°C   |                        |

**Thermal - Mechanical Characteristics**

| Parameters   | Min | Typ | Max  | Units  |
|--|-----|-----|------|--------|
| R <sub>thJC</sub> Thermal Resistance, Junction to Case   |     |     | 0.63 | K/W    |
| R <sub>thCS</sub> ② Thermal Resistance, Case to Heatsink |     | 0.2 |      |        |
| Wt Weight  |     | 5.5 |      | g      |
|  |     | 0.2 |      | (oz)   |
| T Mounting Torque  | 1.2 |     | 2.4  | N * m  |
|  | 10  |     | 20   | lbf.in |

② Mounting Surface, Flat, Smooth and Greased

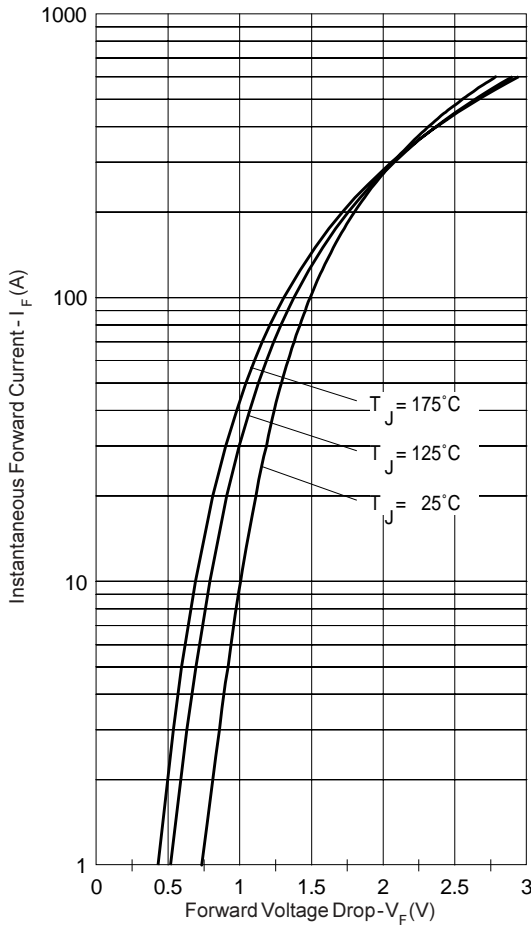


Fig. 1 - Typical Forward Voltage Drop Characteristics

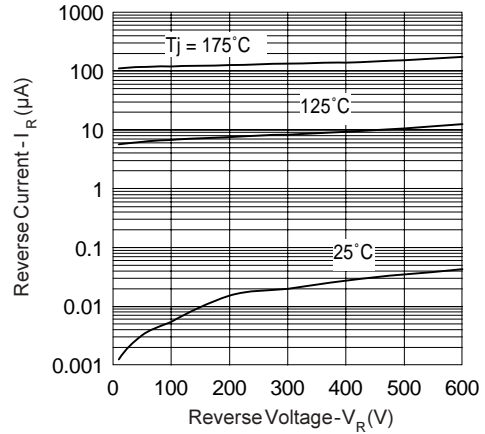


Fig. 2 - Typical Values Of Reverse Current Vs. Reverse Voltage

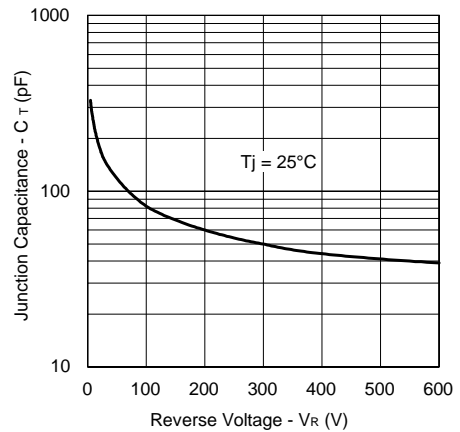


Fig. 3 - Typical Junction Capacitance Vs. Reverse Voltage

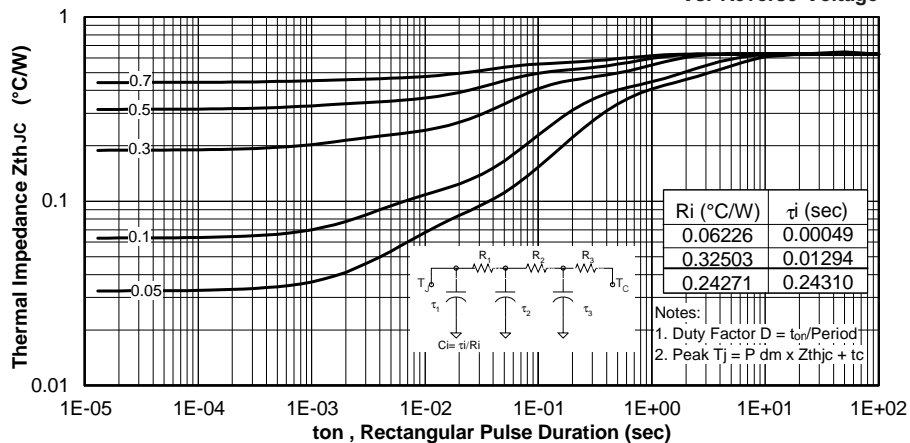
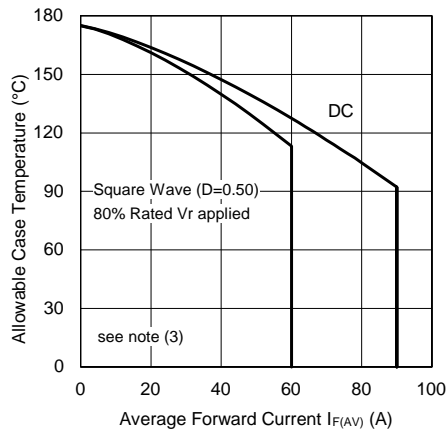
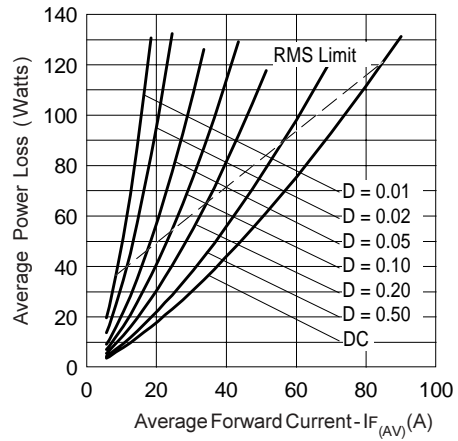


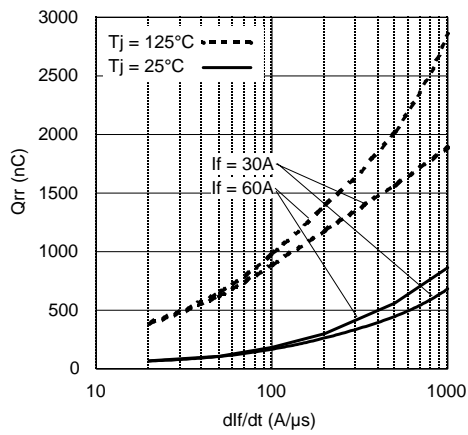
Fig. 4 - Max. Thermal Impedance Z<sub>thJC</sub> Characteristics



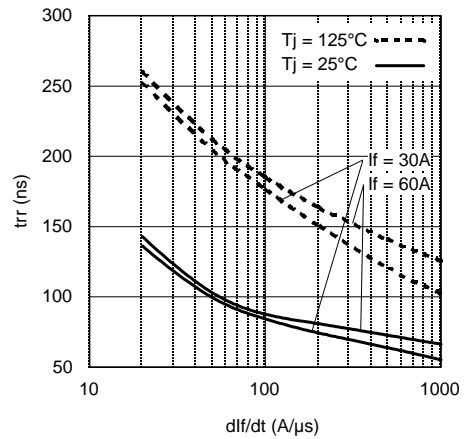
**Fig. 5 - Max. Allowable Case Temperature Vs. Average Forward Current**



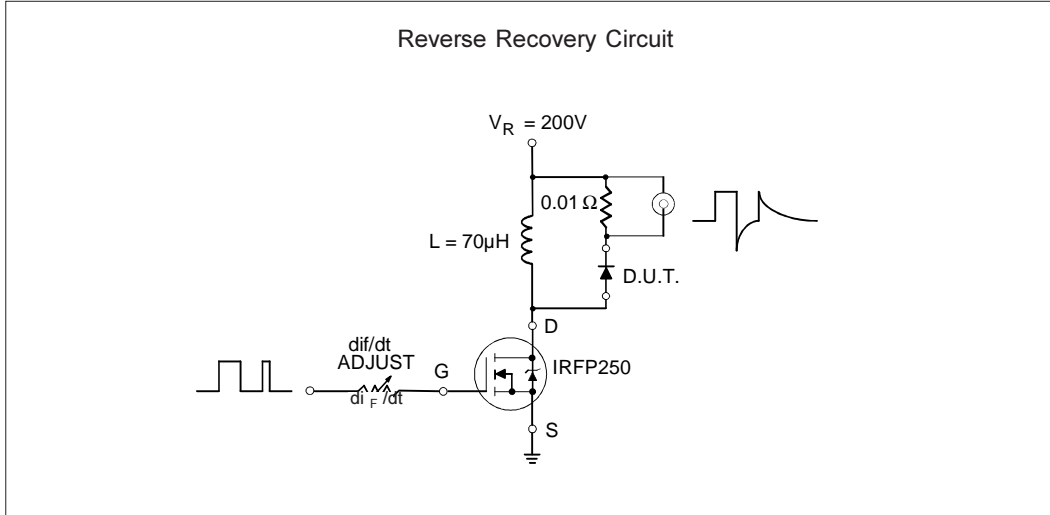
**Fig. 6 - Forward Power Loss Characteristics**



**Fig. 7 - Typical Stored Charge vs. di/dt**

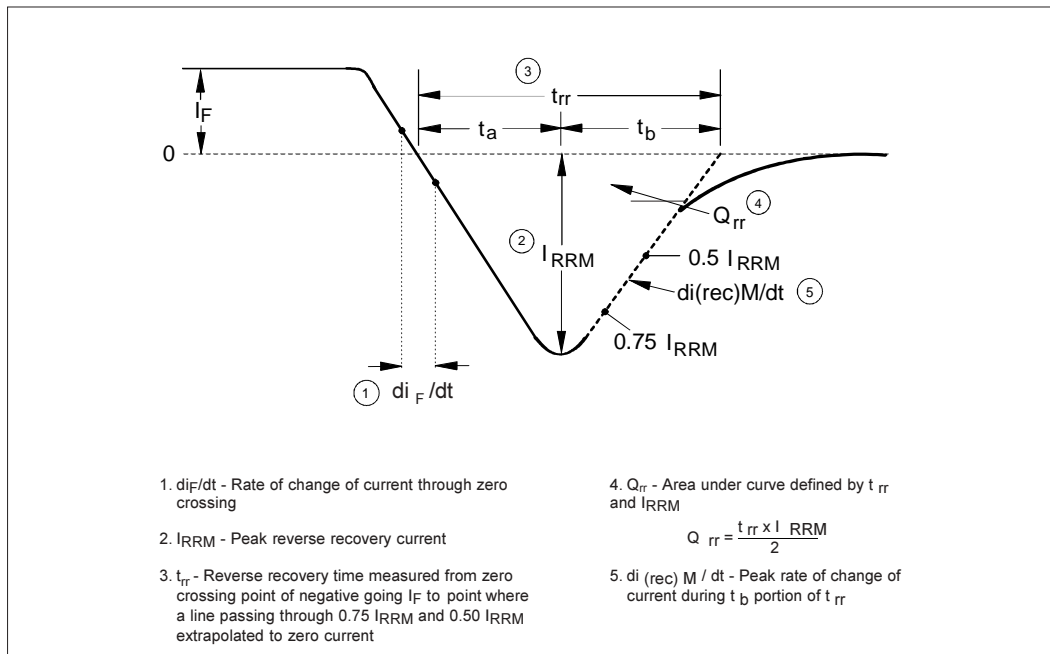


**Fig. 8 - Typical Reverse Recovery Time vs. di/dt**



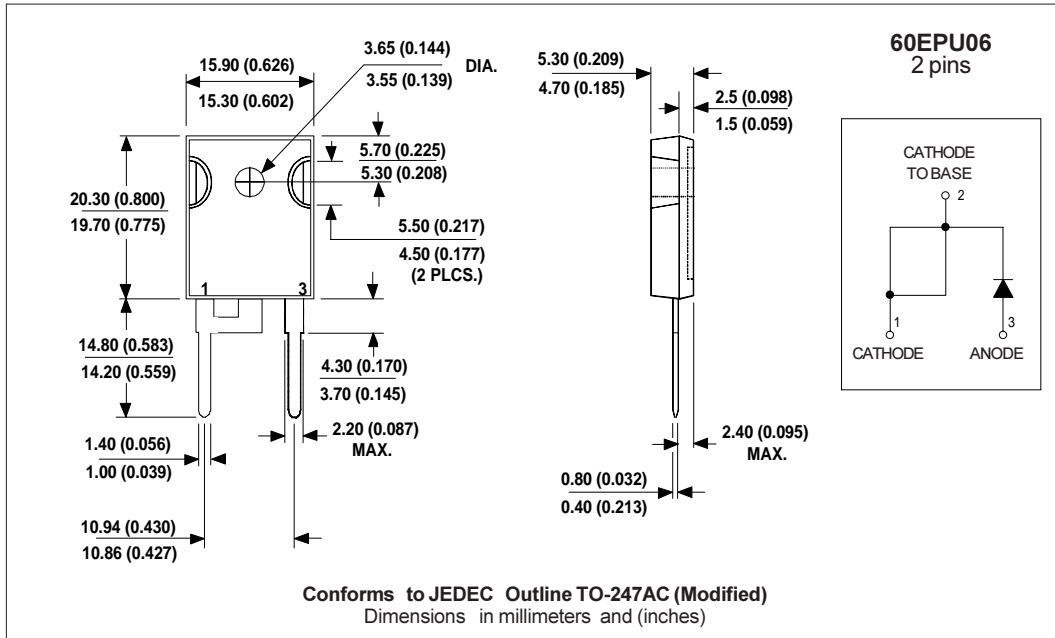
**Fig. 7 - Reverse Recovery Parameter Test Circuit**

- (3) Formula used:  $T_c = T_j - (Pd + Pd_{REV}) \times R_{thJC}$  ;  
 $Pd$  = Forward Power Loss =  $I_{F(AV)} \times V_{FM} @ (I_{F(AV)} / D)$  (see Fig. 6);  
 $Pd_{REV}$  = Inverse Power Loss =  $V_{R1} \times I_R (1 - D)$ ;  $I_R @ V_{R1} = 80\%$  rated  $V_R$

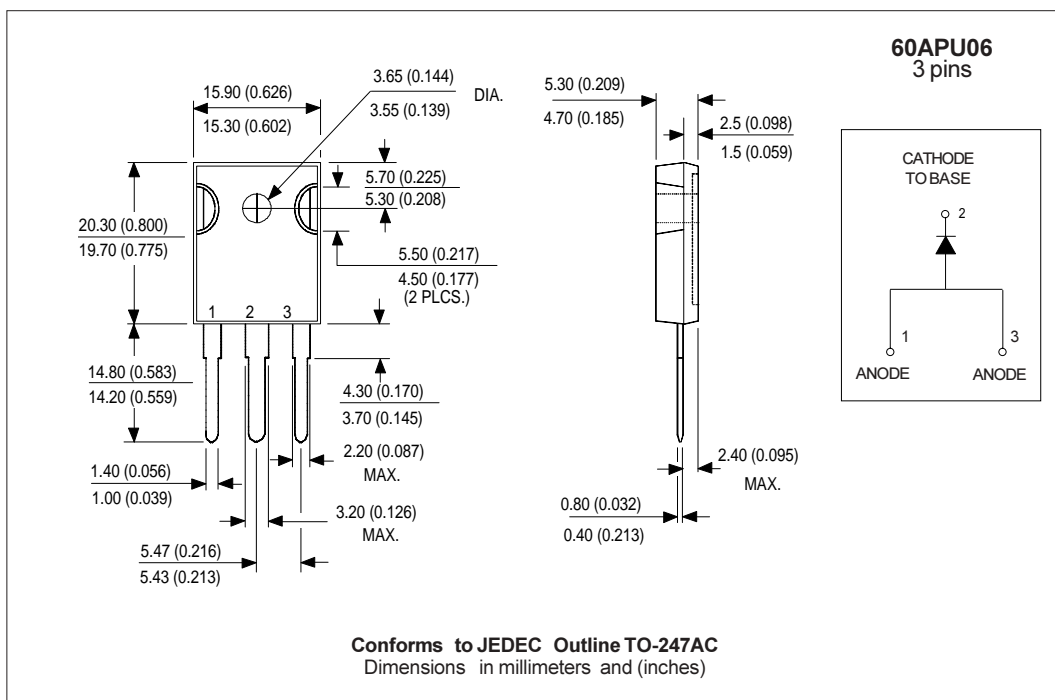


**Fig. 8 - Reverse Recovery Waveform and Definitions**

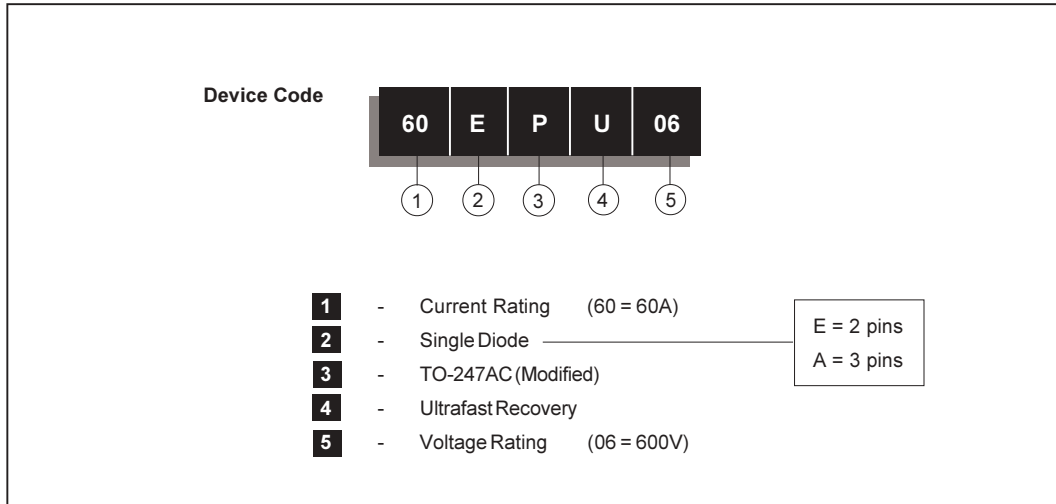
Outline Table



Outline Table



Ordering Information Table



Data and specifications subject to change without notice.  
 This product has been designed and qualified for Industrial Level.  
 Qualification Standards can be found on IR's Web site.



## Notice

The products described herein were acquired by Vishay Intertechnology, Inc., as part of its acquisition of International Rectifier's Power Control Systems (PCS) business, which closed in April 2007. Specifications of the products displayed herein are pending review by Vishay and are subject to the terms and conditions shown below.

Specifications of the products displayed herein are subject to change without notice. Vishay Intertechnology, Inc., or anyone on its behalf, assumes no responsibility or liability for any errors or inaccuracies.

Information contained herein is intended to provide a product description only. No license, express or implied, by estoppel or otherwise, to any intellectual property rights is granted by this document. Except as provided in Vishay's terms and conditions of sale for such products, Vishay assumes no liability whatsoever, and disclaims any express or implied warranty, relating to sale and/or use of Vishay products including liability or warranties relating to fitness for a particular purpose, merchantability, or infringement of any patent, copyright, or other intellectual property right.

The products shown herein are not designed for use in medical, life-saving, or life-sustaining applications. Customers using or selling these products for use in such applications do so at their own risk and agree to fully indemnify Vishay for any damages resulting from such improper use or sale.

International Rectifier®, IR®, the IR logo, HEXFET®, HEXSense®, HEXDIP®, DOL®, INTERO®, and POWIRTRAIN® are registered trademarks of International Rectifier Corporation in the U.S. and other countries. All other product names noted herein may be trademarks of their respective owners.