

23A 500V N-CHANNEL MOSFET

GENERAL DESCRIPTION

SVF23N50PN is an N-channel enhancement mode power MOS field effect transistor which is produced using Silan proprietary F-Cell™ structure VDMOS technology. The improved planar stripe cell and the improved guard ring terminal have been especially tailored to minimize on-state resistance, provide superior switching performance, and withstand high energy pulse in the avalanche and commutation mode. These devices are widely used in AC-DC power suppliers, DC-DC converters and H-bridge PWM motor drivers.

FEATURES

- ◆ 23A, 500V, $R_{DS(on)(typ)}=0.21\Omega@V_{GS}=10V$
- ◆ Low gate charge
- ◆ Low Crss
- ◆ Fast switching
- ◆ Improved dv/dt capability

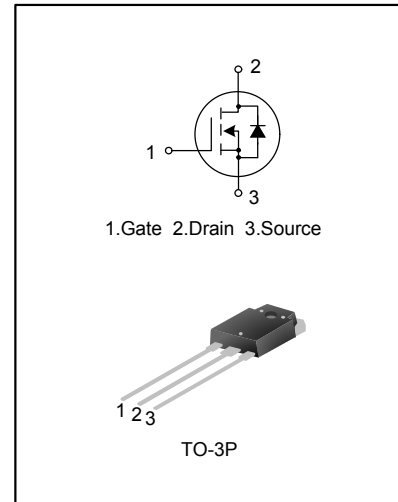

NOMENCLATURE

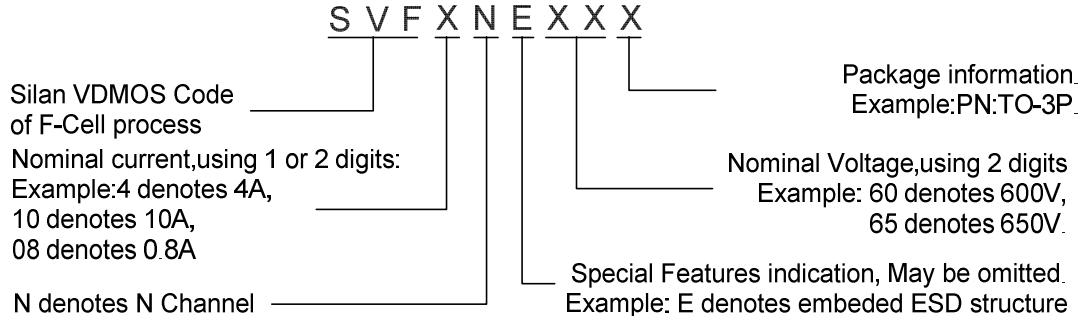

ORDERING INFORMATION

Part No.	Package	Marking	Hazardous Substance Control	Packing
SVF23N50PN	TO-3P	23N50	Pb free	Tube

ABSOLUTE MAXIMUM RATINGS (T_c=25°C unless otherwise noted)

Characteristics		Symbol	Rating	Unit
Drain-Source Voltage		V _{DS}	500	V
Gate-Source Voltage		V _{GS}	±30	V
Drain Current	T _c =25°C	I _D	23.0	A
	T _c =100°C		14.55	
Drain Current Pulsed		I _{DM}	92.0	A
Power Dissipation(T _c =25°C)		P _D	280	W
-Derate above 25°C			2.24	W/°C
Single Pulsed Avalanche Energy (Note 1)		E _{AS}	2044	mJ
Operation Junction Temperature Range		T _J	-55~+150	°C
Storage Temperature Range		T _{stg}	-55~+150	°C

THERMAL CHARACTERISTICS

Characteristics	Symbol	Rating	Unit
Thermal Resistance, Junction-to-Case	R _{θJC}	0.45	°C/W
Thermal Resistance, Junction-to-Ambient	R _{θJA}	50	°C/W

ELECTRICAL CHARACTERISTICS (T_c=25°C unless otherwise noted)

Characteristics	Symbol	Test conditions	Min.	Typ.	Max.	Unit
Drain -Source Breakdown Voltage	B _{VDS}	V _{GS} =0V, I _D =250μA	500	--	--	V
Drain-Source Leakage Current	I _{DSS}	V _{DS} =500V, V _{GS} =0V	--	--	1.0	μA
Gate-Source Leakage Current	I _{GSS}	V _{GS} =±30V, V _{DS} =0V	--	--	±100	nA
Gate Threshold Voltage	V _{GS(th)}	V _{GS} = V _{DS} , I _D =250μA	2.0	--	4.0	V
Static Drain- Source On State Resistance	R _{DS(on)}	V _{GS} =10V, I _D =11.5A	--	0.21	0.27	Ω
Input Capacitance	C _{iss}	V _{DS} =25V, V _{GS} =0V, f=1.0MHz	--	2595.8	--	pF
Output Capacitance	C _{oss}		--	343.8	--	
Reverse Transfer Capacitance	C _{riss}		--	10.1	--	
Turn-on Delay Time	t _{d(on)}	V _{DD} =250V, R _G =10Ω, I _D =23.0A (note 2, 3)	--	42.2	--	ns
Turn-on Rise Time	t _r		--	79.0	--	
Turn-off Delay Time	t _{d(off)}		--	125.7	--	
Turn-off Fall Time	t _f		--	71.2	--	
Total Gate Charge	Q _g	V _{DD} =400V, V _{GS} =10V, I _D =23.0A (note 2, 3)	--	42.51	--	nC
Gate-Source Charge	Q _{gs}		--	12.9	--	
Gate-Drain Charge	Q _{gd}		--	14.34	--	

SOURCE-DRAIN DIODE RATINGS AND CHARACTERISTICS

Characteristics	Symbol	Test conditions	Min.	Typ.	Max.	Unit
Continuous Source Current	I_S	Integral Reverse P-N Junction	--	--	23.0	A
Pulsed Source Current	I_{SM}	Diode in the MOSFET	--	--	92.0	
Diode Forward Voltage	V_{SD}	$I_S=23.0A, V_{GS}=0V$	--	--	1.4	V
Reverse Recovery Time	T_{rr}	$I_S=23.0A, V_{GS}=0V,$	--	578.21	--	ns
Reverse Recovery Charge	Q_{rr}	$di_F/dt=100A/\mu s$ (Note 2)	--	7.89	--	μC

Notes:

1. $L=30mH, I_{AS}=10.65A, V_{DD}=100V, R_G=25\Omega,$ starting $T_J=25^\circ C;$
2. Pulse Test: Pulse width $\leq 300\mu s,$ Duty cycle $\leq 2\%;$
3. Essentially independent of operating temperature.

TYPICAL CHARACTERISTICS

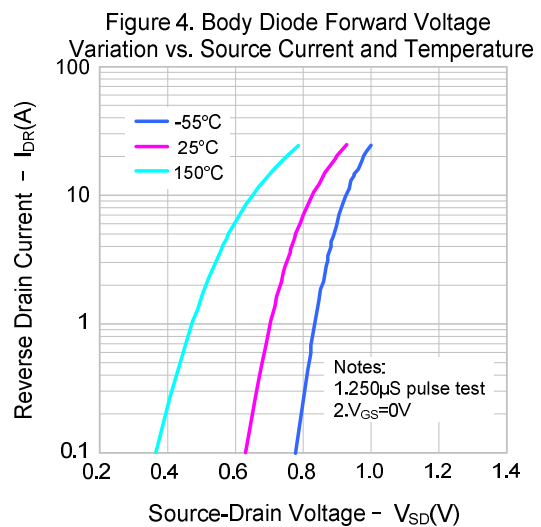
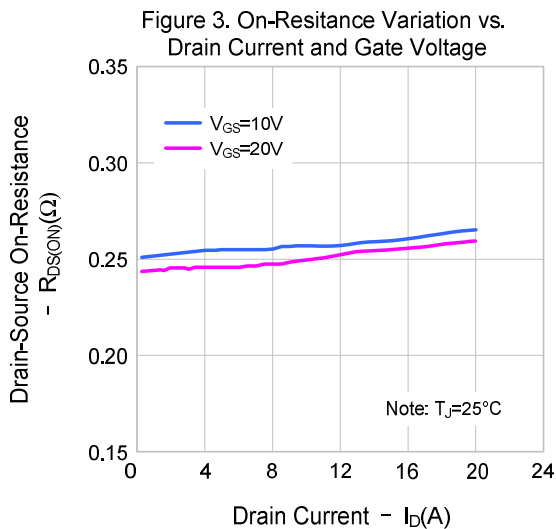
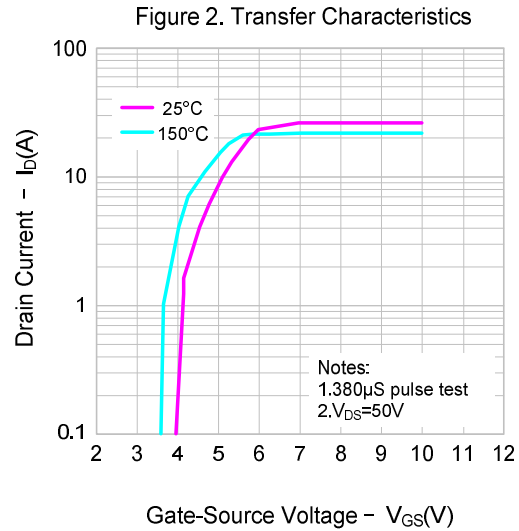
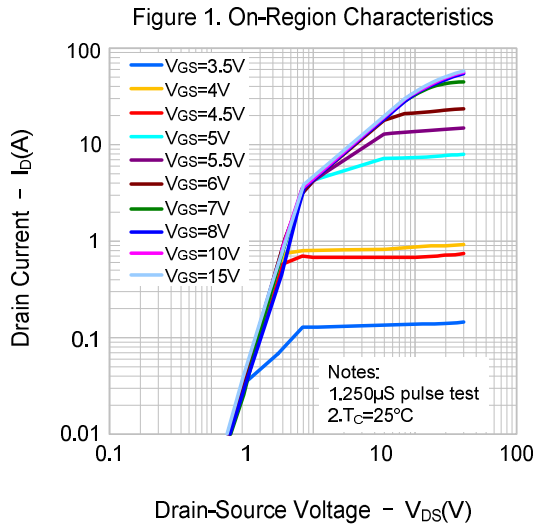

TYPICAL CHARACTERISTICS

Figure 5. Capacitance Characteristics

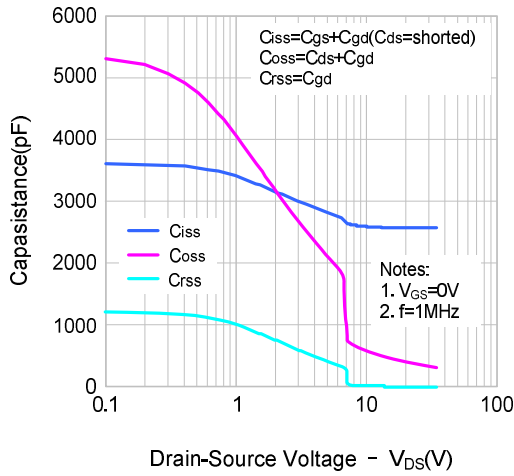

Figure 6. Gate Charge Characteristics

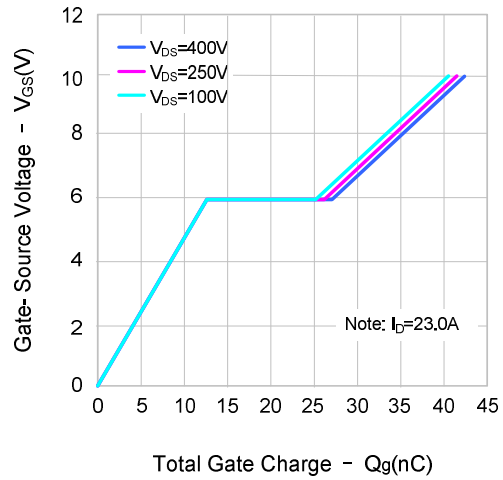

Figure 7. Breakdown Voltage Variation vs. Temperature

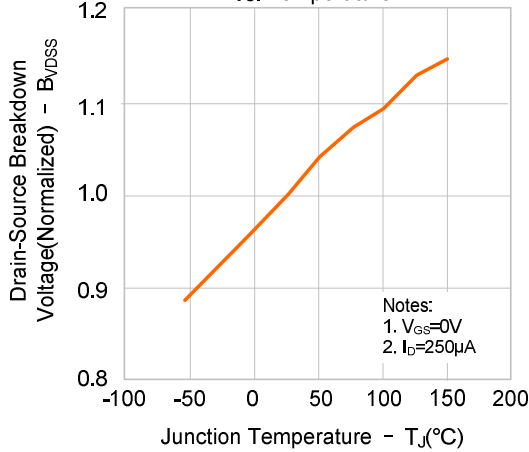

Figure 8. On-resistance Variation vs. Temperature

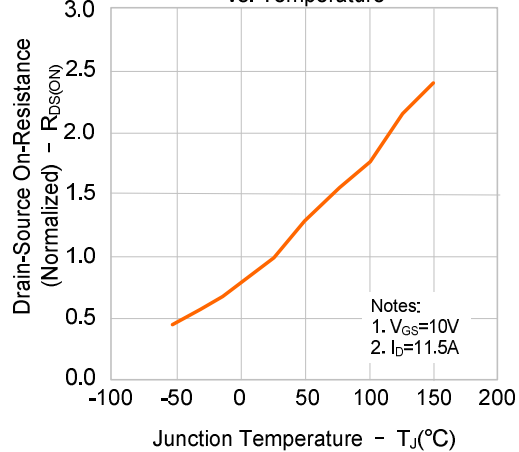

Figure 9. Max. Safe Operating Area

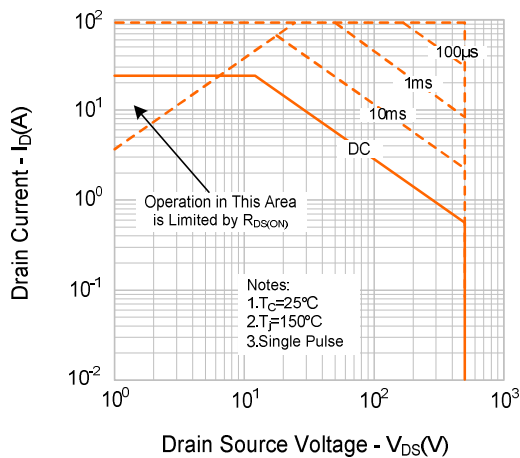
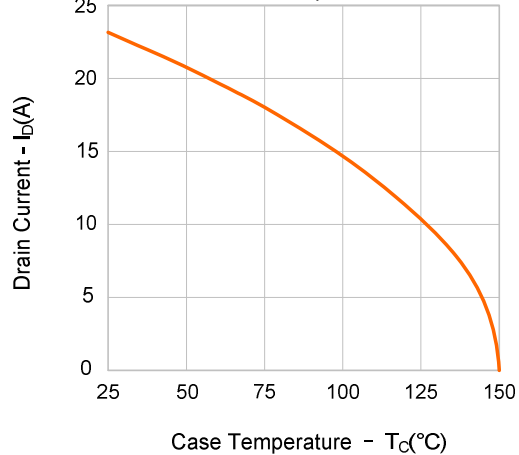
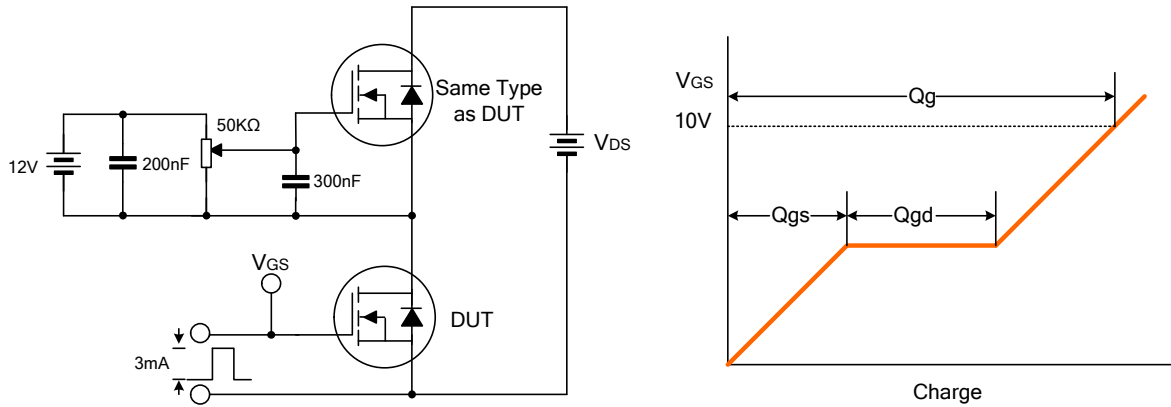

Figure 10. Maximum Drain Current vs. Case Temperature



TYPICAL TEST CIRCUIT

Gate Charge Test Circuit & Waveform



Resistive Switching Test Circuit & Waveform

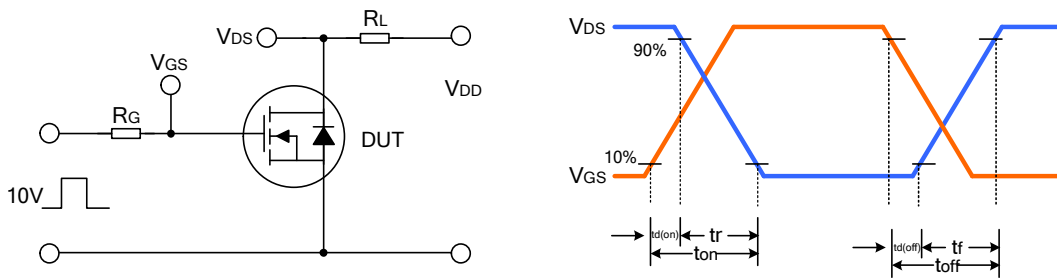

Unclamped Inductive Switching Test Circuit & Waveform

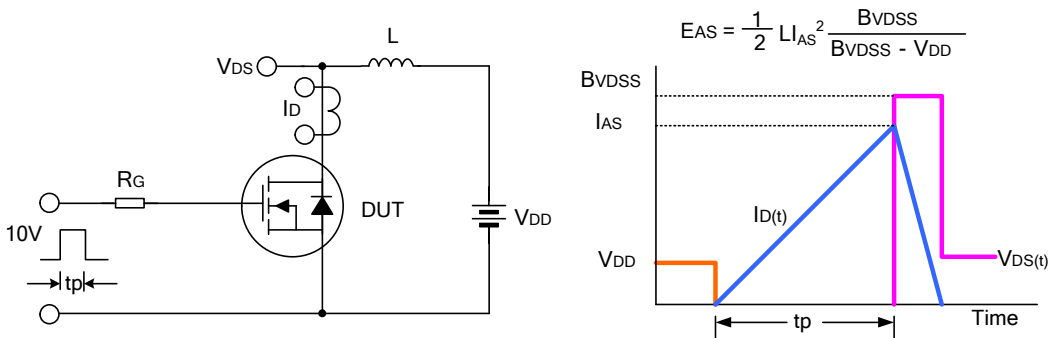

PACKAGE OUTLINE

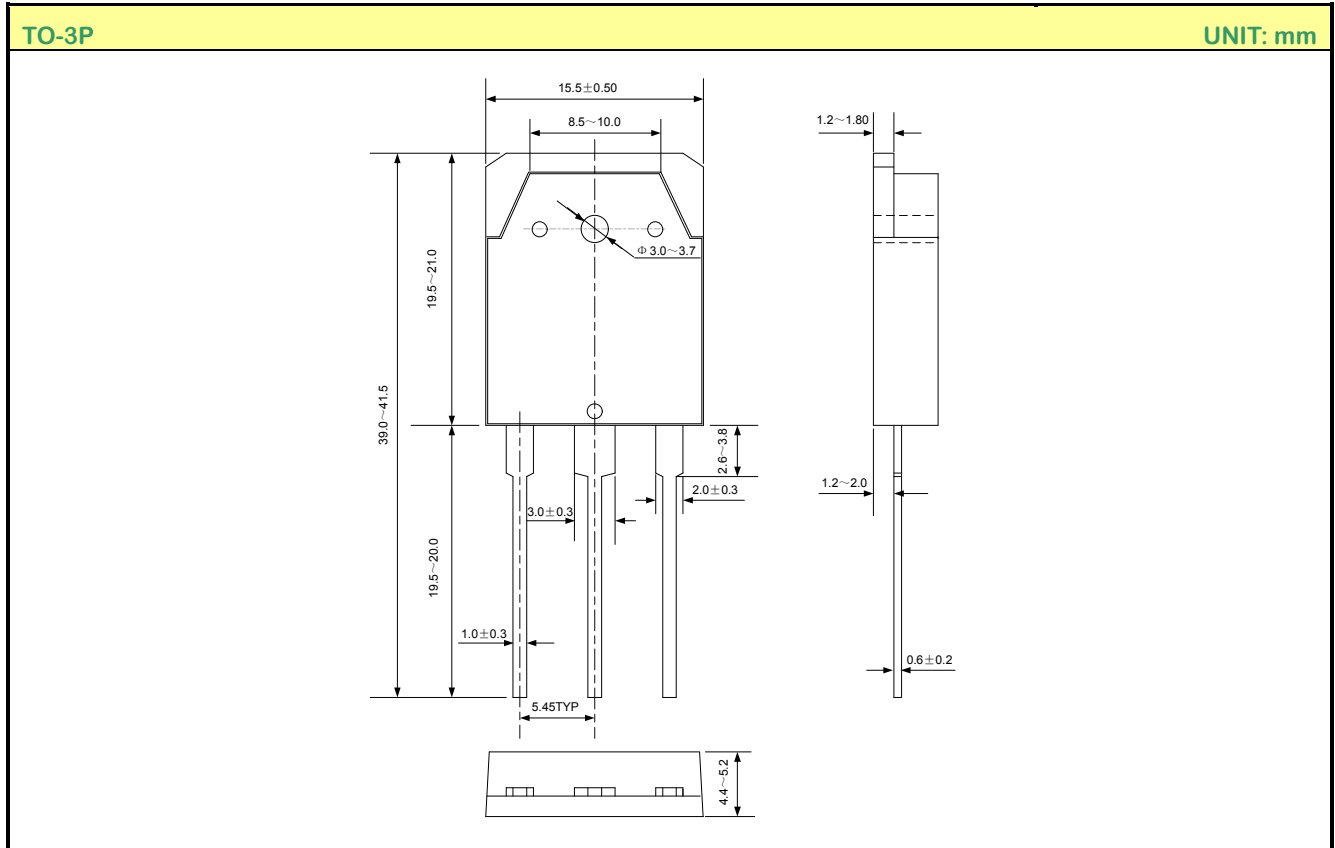

Disclaimer :

- Silan reserves the right to make changes to the information herein for the improvement of the design and performance without prior notice! Customers should obtain the latest relevant information before placing orders and should verify that such information is complete and current.
- All semiconductor products malfunction or fail with some probability under special conditions. When using Silan products in system design or complete machine manufacturing, it is the responsibility of the buyer to comply with the safety standards strictly and take essential measures to avoid situations in which a malfunction or failure of such Silan products could cause loss of body injury or damage to property.
- Silan will supply the best possible product for customers!

Part No.: SVF23N50PN Document Type: Datasheet
Copyright: HANGZHOU SILAN MICROELECTRONICS CO.,LTD Website: <http://www.silan.com.cn>

Rev.: 1.1 Author: Yin Zi

Revision History:

1. Modify ordering information
2. Modify Part No.

Rev.: 1.0 Author: Yin Zi

Revision History:

1. First release
-