



TDA7377

LINEAR INTEGRATED CIRCUIT

2 x 30W DUAL/QUAD POWER AMPLIFIER FOR CAR RADIO

DESCRIPTION

The UTC **TDA7377** is a class AB car radio amplifier for car radio, it can work either in dual bridge or quad single ended configuration. The exclusive fully complementary structure of the output stage and the internally fixed gain guarantees the highest possible power performances with few external components. The on-board clip detector simplifies gain compression operation. The fault diagnostics makes it possible to detect mistakes during car radio set assembly and wiring in the car.

FEATURES

- * High Output Power@ $V_{CC}=14.4V$, $f=1KHz$, $R_L=4\Omega$:
 - 2 x 35W Max.
 - 2 x 20W@THD= 10%
 - 4 x 6 W @10%
 - 4 x 10W / 2Ω @10%
 - 2 x 30W / EIAJ@ $V_{CC} = 13.7V$, $R_L=4\Omega$
- * CMOS Compatible Stand-by Function (Low I_{CC})
- * No Audible pop During st-by Operations
- * Internally Fixed Gain (26dB BTL and 20dB single ended)
- * No Bootstrap Capacitors and boucherot Cells
- * Diagnostics Facility on pin10 when output Clipping, shorted to V_{CC} or GND, thermal shutdown and soft short at turn on.
- * Rail to rail output swing
- * Absolute Stability Without Any External Compensation.

ORDERING INFORMATION

Ordering Number		Package	Packing
Lead Free	Halogen Free		
TDA7377L-J15-A-T	TDA7377G-J15-A-T	HZIP-15A	Tube
TDA7377L-J15-D-T	TDA7377G-J15-D-T	HZIP-15D	Tube

<p>TDA7377L-J15-A-T</p> <ul style="list-style-type: none"> (1) Packing Type (2) Package Type (3) Lead Free 	<ul style="list-style-type: none"> (1) T: Tube (2) J15-A:HZIP-15A, J15-D: HZIP-15D (3) L: Lead Free, G: Halogen Free
---	---

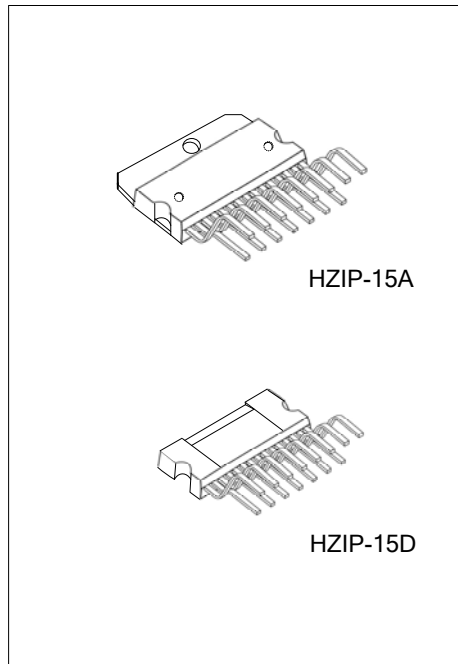

PROTECTIONS

- * Load Dump Voltages surge
- * Reversed Battery
- * Output DC Short Circuit protection with Low current when shorted to GND or V_{CC} .
- * Output AC short circuit protection: across the load
- * Silent Turn On/Off
- * thermal shutdown
- * Load very Inductive speakers
- * Fortuitous Open GND
- * ESD

■ PIN CONNECTION

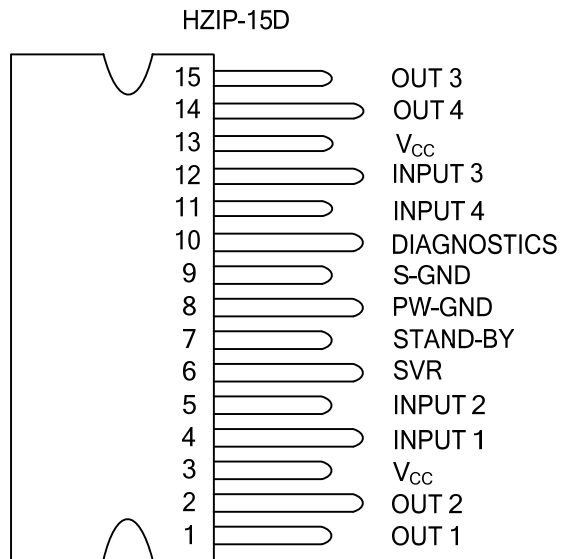
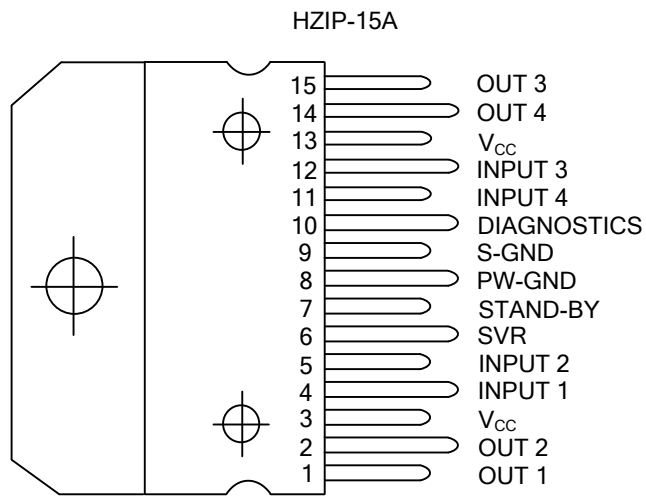

■ BLOCK DIAGRAM

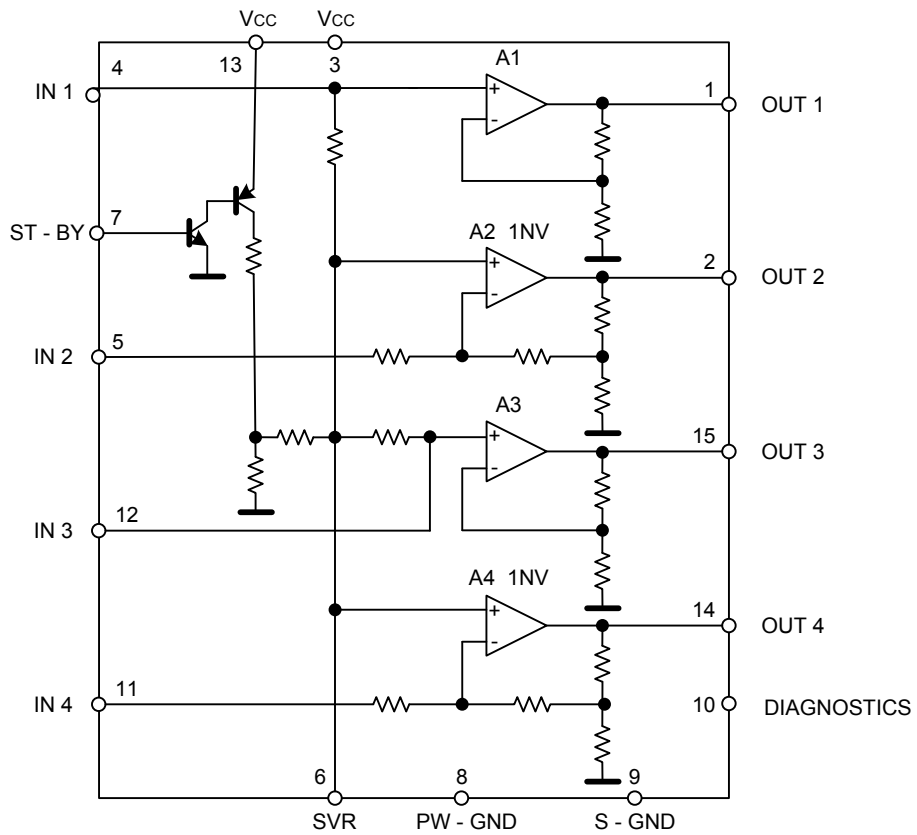

■ ABSOLUTE MAXIMUM RATINGS

PARAMETER		SYMBOL	RATINGS	UNIT
Operating Supply Voltage		V_{OP}	18	V
DC Supply Voltage		V_S	28	V
Peak Supply Voltage (for $t = 50\text{ms}$)		$V_{S(PEAK)}$	50	V
Output Peak Current	not Repetitive $t = 100\mu\text{s}$	$I_{O(PEAK)}$	4.5	A
	Repetitive $f > 10\text{Hz}$		3.5	A
Power Dissipation ($T_C = 70^\circ\text{C}$)	HZIP-15A	P_D	33	W
	HZIP-15D		30	
Junction Temperature		T_J	+150	$^\circ\text{C}$
Storage Temperature		T_{STG}	-40~+150	$^\circ\text{C}$

Note: Absolute maximum ratings are those values beyond which the device could be permanently damaged.

Absolute maximum ratings are stress ratings only and functional device operation is not implied.

■ THERMAL DATA

PARAMETER		SYMBOL	RATINGS	UNIT
Junction to Case	HZIP-15A	θ_{JC}	1.4	$^\circ\text{C/W}$
	HZIP-15D		1.8	

■ ELECTRICAL CHARACTERISTICS

($V_S = 14.4V$; $R_L = 4\Omega$; $f = 1\text{ KHz}$; $T_A = 25^\circ\text{C}$, unless otherwise specified)

PARAMETER	SYMBOL	TEST CONDITIONS	MIN	TYP	MAX	UNIT
Supply Voltage Range	V_S		8		18	V
ST-BY Threshold Voltage	IN	$V_{I(ST-BY)}$			1.5	V
	OUT	$V_{O(ST-BY)}$	3.5			
Voltage Saturation on pin 10	V_{SAT}	Sink Current at Pin 10 = 1mA			0.7	V
Output Offset Voltage	$V_{O(OFF)}$				150	mV
Input Noise Voltage	eN	Rg = 0; S.E. Non Inverting Channels		2		μV
		"A" weighted, Inverting Channels		5		
		Bridge, Rg = 0; 22Hz ~ 22KHz		3.5		μV
Total Quiescent Drain Current	I_Q	$R_L = \infty$			150	mA
ST-BY Pin Current(pin 7)	I_{ST-BY}	Max Driving Current Under Fault			5	mA
		Play Mode Vpin7 = 5V			50	μA
ST-BY Current Consumption	I_{ST-BY}	$V_{ST-BY} = 0 \sim 1.5V$			100	μA
Clipping Detector Output	OFF	$I_{CD(OFF)}$	d = 1% (Note 2)	90		μA
Average Current	ON	$I_{CD(ON)}$	d = 5% (Note 2)	160		μA
Input Impedance	R_{IN}	Single Ended	20	30		K Ω
		Bridge	10	15		
Output Power	P_{OUT}	THD = 10%; Bridge	18	20		W
		$R_L = 4\Omega$; Single Ended	5.5	6		
		Single Ended, $R_L = 2\Omega$		10		
Output Power (Note 3)	Max	$P_{O(MAX)}$	$V_S = 14.4V$, Bridge	31	35	W
	EIAJ	$P_{O(EIAJ)}$	$V_S = 13.7V$, Bridge	27	30	W
Distortion	THD	$R_L = 4\Omega$	Single Ended, $P_{OUT} = 0.1 \sim 4W$		0.02	%
			Bridge, $P_{OUT} = 0.1 \sim 10W$		0.03	
Cross Talk	CT	f = 1KHz Single Ended		70		dB
		f = 10KHz Single Ended		60		dB
		f = 1KHz Bridge	55			dB
		f = 10KHz Bridge		60		dB
Voltage Gain	G_V	Single Ended	19	20	21	dB
		Bridge	25	26	27	dB
Voltage Gain Match	G_V				0.5	dB
Supply Voltage Rejection	SVR	$R_g = 0$; $f = 300\text{Hz}$	50			dB
Stand-by Attenuation	A_{ST-BY}	$P_O = 1W$	80	90		dB

- Note: 1. See built-in S/C protection description
 2. Pin 10 Pulled-up to 5V with 10K Ω ; $R_L = 4\Omega$
 3. Saturated square wave output.

■ TYPICAL TEST AND APPLICATION CIRCUIT

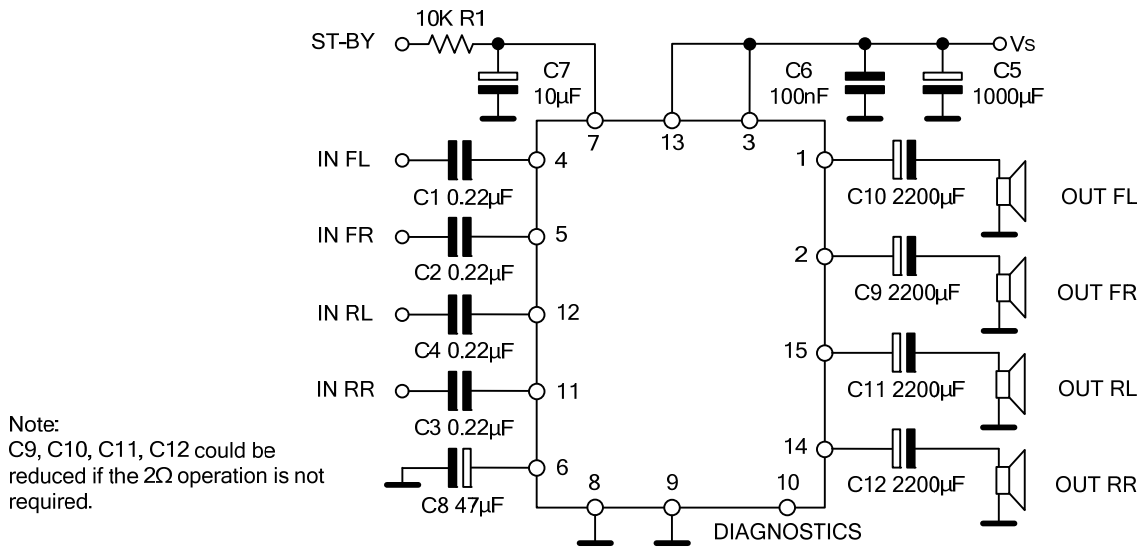

Figure 1. Quad Stereo

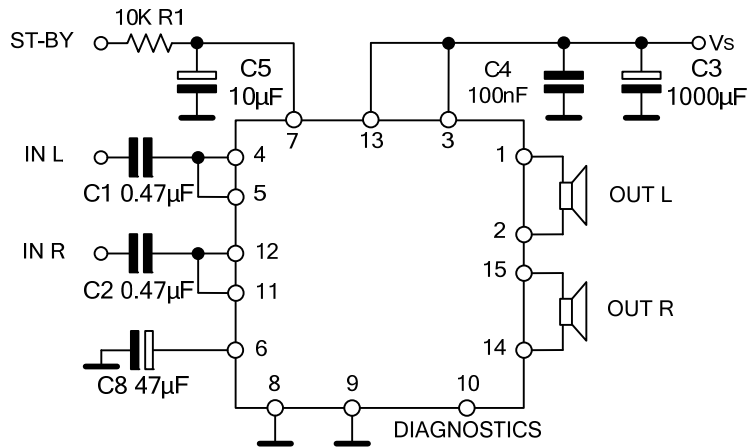

Figure 2. Double Bridge

■ TYPICAL TEST AND APPLICATION CIRCUIT (Cont.)

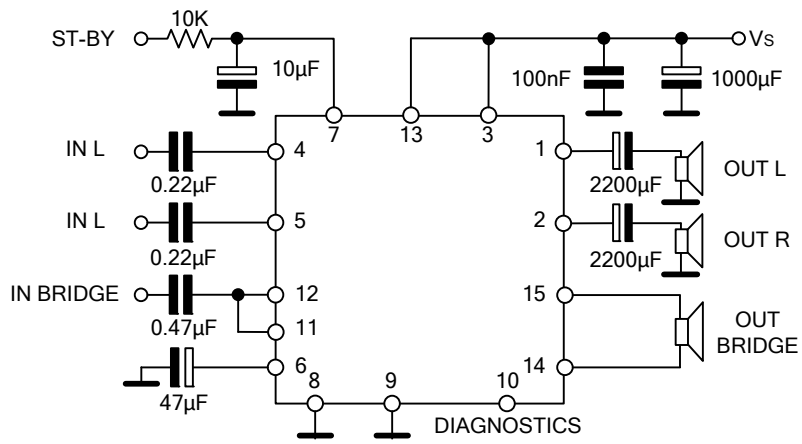

Figure 3. Stereo/Bridge

■ TYPICAL APPLICATION INFORMATION

Diagnostics Facility note:

UTC **TDA7377** built in a diagnostic circuitry, when following events appearing: clipping in the output signal, thermal shutdown, and output fault including short to GND, short to V_S and soft short at turn on.

When the event is detected, The information is available across an open collector output (pin 10) through a current sinking (see Fig 4).The current sinking at pin 10 is triggered when a certain distortion level is reached at any of the outputs. This function allows gain compression possibility whenever the amplifier is overdriven. The current sinking at pin 10 also can be triggered When the IC's operating temperature raise to about 10°C before the shutdown threshold.

Normally the clip detector signaling produces a low level at pin 10 that is shorter than that present under faulty conditions; This can be used to discriminate each event (clipping detection, output fault, thermal proximity).

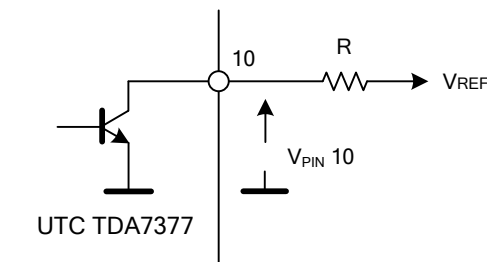

Figure 4. Pin10 Diagnostic Circuitry

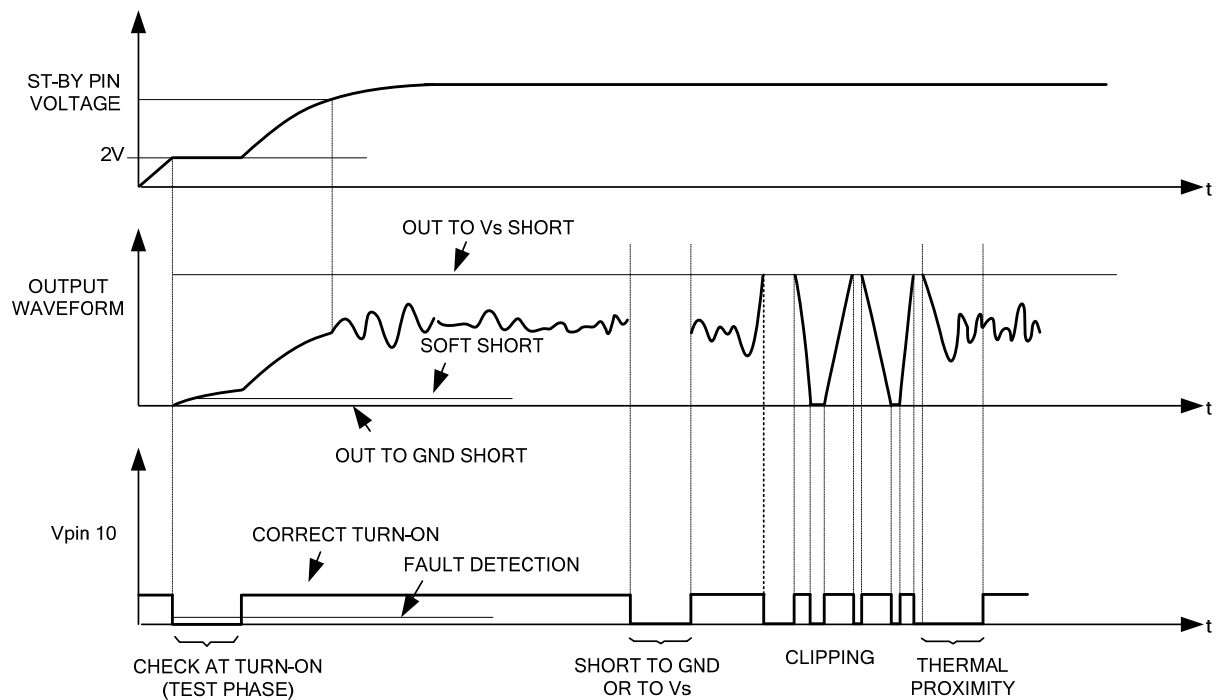
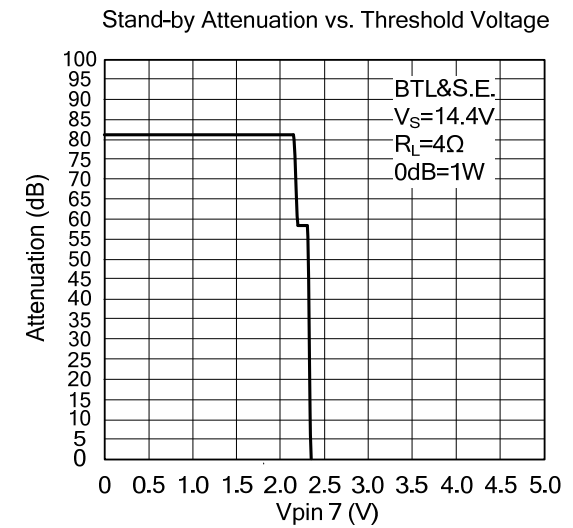
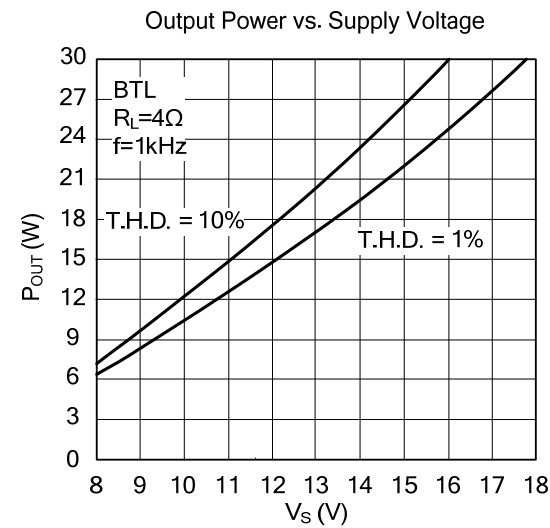
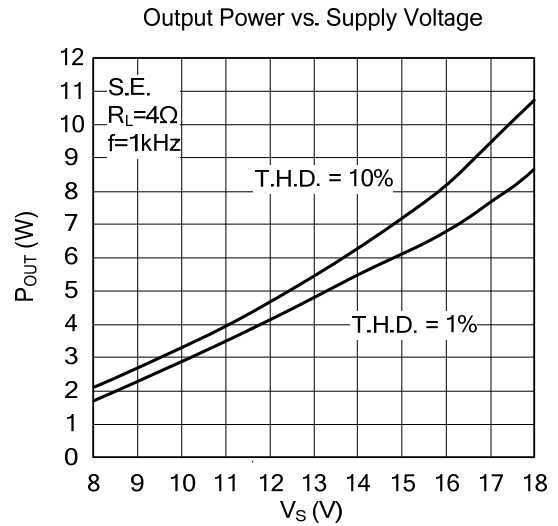
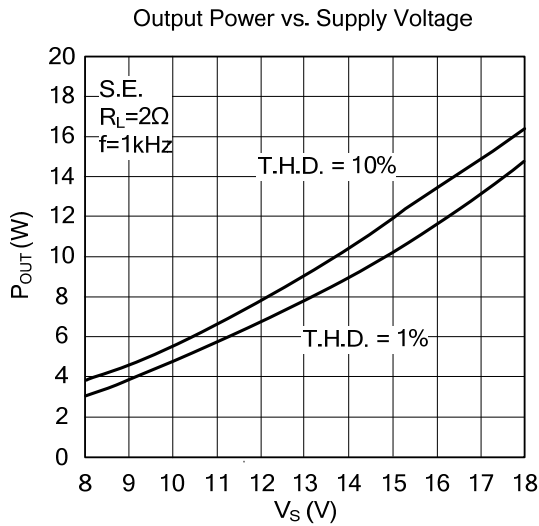
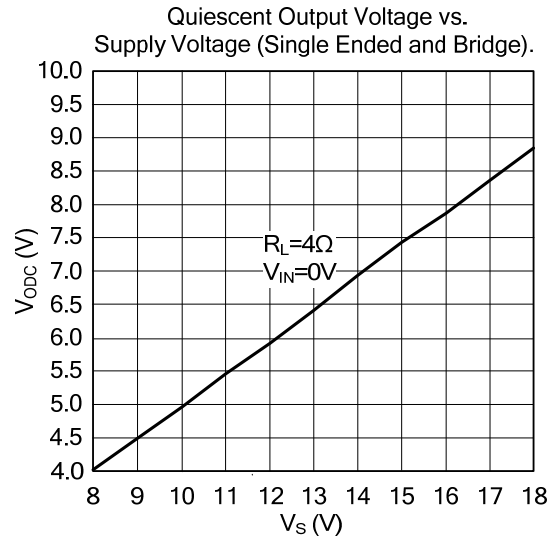
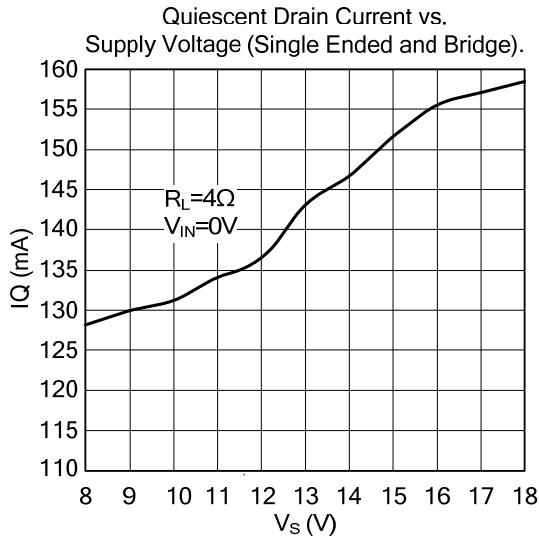

Figure 5. Waveforms

TYPICAL CHARACTERISTICS



UTC assumes no responsibility for equipment failures that result from using products at values that exceed, even momentarily, rated values (such as maximum ratings, operating condition ranges, or other parameters) listed in products specifications of any and all UTC products described or contained herein. UTC products are not designed for use in life support appliances, devices or systems where malfunction of these products can be reasonably expected to result in personal injury. Reproduction in whole or in part is prohibited without the prior written consent of the copyright owner. The information presented in this document does not form part of any quotation or contract, is believed to be accurate and reliable and may be changed without notice.