

# DATA SHEET



## **TDA9870A** Digital TV Sound Processor (DTVSP)

Product specification  
File under Integrated Circuits, IC02

1998 Aug 10

---

**Digital TV Sound Processor (DTVSP)****TDA9870A**

---

**CONTENTS**

1	FEATURES
1.1	Demodulator and decoder section
1.2	DSP section
1.3	Analog audio section
2	GENERAL DESCRIPTION
2.1	Supported standards
3	ORDERING INFORMATION
4	BLOCK DIAGRAM
5	PINNING
6	FUNCTIONAL DESCRIPTION
6.1	Description of the demodulator and decoder section
6.2	Description of the DSP
6.3	Description of the analog audio section
7	LIMITING VALUES
8	THERMAL CHARACTERISTICS
9	CHARACTERISTICS
10	I <sup>2</sup> C-BUS CONTROL
10.1	Introduction
10.2	Power-up state
10.3	Slave receiver mode
10.4	Slave transmitter mode
10.5	Expert mode
11	I <sup>2</sup> S-BUS DESCRIPTION
12	EXTERNAL COMPONENTS
13	APPLICATION CIRCUITRY
14	PACKAGE OUTLINE
15	SOLDERING
15.1	Introduction
15.2	Soldering by dipping or by wave
15.3	Repairing soldered joints
16	DEFINITIONS
17	LIFE SUPPORT APPLICATIONS
18	PURCHASE OF PHILIPS I <sup>2</sup> C COMPONENTS

# Digital TV Sound Processor (DTVSP)

# TDA9870A

## 1 FEATURES

### 1.1 Demodulator and decoder section

- Sound IF (SIF) input switch e.g. to select between terrestrial TV SIF and SAT SIF sources
- SIF AGC with 24 dB control range
- SIF 8-bit Analog-to-Digital Converter (ADC)
- Two-carrier multistandard FM demodulation (B/G, D/K and M standard)
- Decoding for three analog multi-channel systems (A2, A2+ and A2\*) and satellite sound
- Programmable identification (B/G, D/K and M standard) and different identification times.

### 1.2 DSP section

- Digital crossbar switch for all digital signal sources and destinations
- Control of volume, balance, contour, bass, treble, pseudo stereo, spatial, bass boost and soft-mute
- Plop-free volume control
- Automatic Volume Level (AVL) control
- Adaptive de-emphasis for satellite
- Programmable beeper
- Monitor selection for FM/AM DC values and signals, with peak detection option
- I<sup>2</sup>S-bus interface for a feature extension (e.g. Dolby surround) with matrix, level adjust and mute.

### 1.3 Analog audio section

- Analog crossbar switch with inputs for mono and stereo (also applicable as SCART 3 input), SCART 1 input/output, SCART 2 input/output and line output
- User defined full-level/−3 dB scaling for SCART outputs
- Output selection of mono, stereo, dual A/B, dual A or dual B
- 20 kHz bandwidth for SCART-to-SCART copies
- Standby mode with functionality for SCART copies
- Dual audio Digital-to-Analog Converter (DAC) from DSP to analog crossbar switch, bandwidth of 15 kHz
- Dual audio ADC from analog inputs to DSP
- Two dual audio DACs for loudspeaker (Main) and headphone (Auxiliary) outputs; also applicable for L, R, C and S in the Dolby Pro Logic mode with feature extension.



## 2 GENERAL DESCRIPTION

The TDA9870A is a single-chip Digital TV Sound Processor (DTVSP) for analog multi-channel sound systems in TV sets and satellite receivers.

### 2.1 Supported standards

The multistandard/multi-stereo capability of the TDA9870A is mainly of interest in Europe, but also in Hong Kong/Peoples Republic of China and South East Asia. This includes B/G, D/K, I, M and L standard. In other application areas there exists only subsets of those standard combinations otherwise only single standards are transmitted.

M standard is transmitted in Europe by the American Forces Network (AFN) with European channel spacing (7 MHz VHF, 8 MHz UHF) and monaural sound.

Korea has a stereo sound system similar to Europe and is supported by the TDA9870A. Differences include deviation, modulation contents and identification. It is based on M standard.

An overview of the supported standards and sound systems and their key parameters is given in Table 1.

The analog multi-channel sound systems (A2, A2+ and A2\*) are sometimes also named 2CS (2-Carrier Systems).

## Digital TV Sound Processor (DTVSP)

## TDA9870A

## 2.1.1 ANALOG 2-CARRIER SYSTEMS

**Table 1** Frequency modulation

STANDARD	SOUND SYSTEM	CARRIER FREQUENCY (MHz)	FM DEVIATION (kHz)			MODULATION		BANDWIDTH/ DE-EMPHASIS (kHz/ $\mu$ s)
			NOM.	MAX.	OVER	SC1	SC2	
M	mono	4.5	15	25	50	mono	–	15/75
M	A2+	4.5/4.724	15	25	50	$\frac{1}{2}(L + R)$	$\frac{1}{2}(L - R)$	15/75 (Korea)
B/G	A2	5.5/5.742	27	50	80	$\frac{1}{2}(L + R)$	R	15/50
I	mono	6.0	27	50	80	mono	–	15/50
D/K	A2	6.5/6.742	27	50	80	$\frac{1}{2}(L + R)$	R	15/50
D/K	A2*	6.5/6.258	27	50	80	$\frac{1}{2}(L + R)$	R	15/50

**Table 2** Identification for A2 systems

PARAMETER	A2/A2*	A2+ (KOREA)
Pilot frequency	54.6875 kHz = $3.5 \times$ line frequency	55.0699 kHz = $3.5 \times$ line frequency
Stereo identification frequency	117.5 Hz = $\frac{\text{line frequency}}{133}$	149.9 Hz = $\frac{\text{line frequency}}{105}$
Dual identification frequency	274.1 Hz = $\frac{\text{line frequency}}{57}$	276.0 Hz = $\frac{\text{line frequency}}{57}$
AM modulation depth	50%	50%

## Digital TV Sound Processor (DTVSP)

TDA9870A

## 2.1.2 SATELLITE SYSTEMS

An important specification for satellite TV reception is the "Astra specification". The TDA9870A is suited for the reception of Astra and other satellite signals.

**Table 3** FM satellite sound

CARRIER TYPE	CARRIER FREQUENCY (MHz)	MODULATION INDEX	MAXIMUM FM DEVIATION (kHz)	MODULATION	BANDWIDTH/ DE-EMPHASIS (kHz/ $\mu$ s)
Main	6.50 <sup>(1)</sup>	0.26	85	mono	15/50 <sup>(1)</sup>
Sub	7.02/7.20	0.15	50	m/st/d <sup>(2)</sup>	15/adaptive <sup>(3)</sup>
Sub	7.38/7.56	0.15	50	m/st/d <sup>(2)</sup>	15/adaptive <sup>(3)</sup>
Sub	7.74/7.92	0.15	50	m/st/d <sup>(2)</sup>	15/adaptive <sup>(3)</sup>
Sub	8.10/8.28	0.15	50	m/st/d <sup>(2)</sup>	15/adaptive <sup>(3)</sup>

**Notes**

- For other satellite systems, frequencies of, for example, 5.80, 6.60 or 6.65 MHz can also be received. A de-emphasis of 60  $\mu$ s, or in accordance with J17, is available.
- m/st/d = mono or stereo or dual language sound.
- Adaptive de-emphasis is compatible to transmitter specification.

**3 ORDERING INFORMATION**

TYPE NUMBER	PACKAGE		
	NAME	DESCRIPTION	VERSION
TDA9870A	SDIP64	plastic shrink dual in-line package; 64 leads (750 mil)	SOT274-1

Digital TV Sound Processor (DTVSP)

TDA9870A

4 BLOCK DIAGRAM

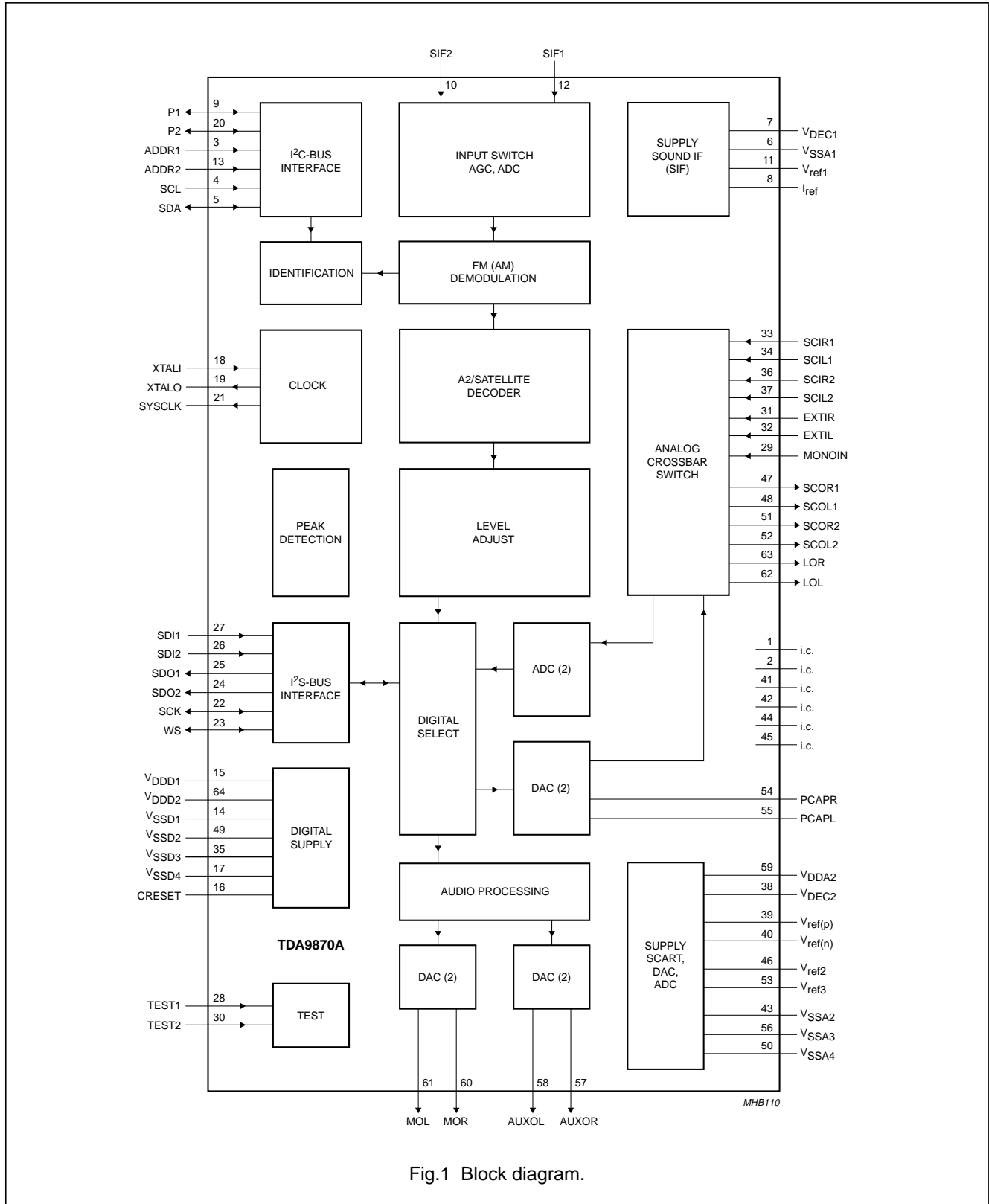

Fig.1 Block diagram.

## Digital TV Sound Processor (DTVSP)

TDA9870A

## 5 PINNING

SYMBOL	PIN	I/O	DESCRIPTION
i.c.	1	–	internally connected; note 1
i.c.	2	–	internally connected; note 1
ADDR1	3	I	first I <sup>2</sup> C-bus slave address modifier
SCL	4	I	I <sup>2</sup> C-bus clock input
SDA	5	I/O	I <sup>2</sup> C-bus data input/output
V <sub>SSA1</sub>	6	supply	supply ground 1; analog front-end circuitry
V <sub>DEC1</sub>	7	–	positive power supply voltage 1 decoupling; analog front-end circuitry
I <sub>ref</sub>	8	–	resistor for reference current generator; analog front-end circuitry
P1	9	I/O	first general purpose I/O pin
SIF2	10	I	sound IF input 2
V <sub>ref1</sub>	11	–	reference voltage; analog front-end circuitry
SIF1	12	I	sound IF input 1
ADDR2	13	I	second I <sup>2</sup> C-bus slave address modifier
V <sub>SSD1</sub>	14	supply	supply ground 1; digital circuitry
V <sub>DD1</sub>	15	supply	digital supply voltage 1; digital circuitry
CRESET	16	–	capacitor for power-on reset
V <sub>SSD4</sub>	17	supply	supply ground 4; digital circuitry
XTALI	18	I	crystal oscillator input
XTALO	19	O	crystal oscillator output
P2	20	I/O	second general purpose I/O pin
SYSCLK	21	O	system clock output
SCK	22	I/O	I <sup>2</sup> S-bus clock input/output
WS	23	I/O	I <sup>2</sup> S-bus word select input/output
SDO2	24	O	I <sup>2</sup> S-bus data output 2
SDO1	25	O	I <sup>2</sup> S-bus data output 1
SDI2	26	I	I <sup>2</sup> S-bus data input 2
SDI1	27	I	I <sup>2</sup> S-bus data input 1
TEST1	28	I	first test pin; connected to V <sub>SSD1</sub> for normal operation
MONOIN	29	I	audio mono input
TEST2	30	I	second test pin; connected to V <sub>SSD1</sub> for normal operation
EXTIR	31	I	external audio input right channel
EXTIL	32	I	external audio input left channel
SCIR1	33	I	SCART 1 input right channel
SCIL1	34	I	SCART 1 input left channel
V <sub>SSD3</sub>	35	supply	supply ground 3; digital circuitry
SCIR2	36	I	SCART 2 input right channel
SCIL2	37	I	SCART 2 input left channel
V <sub>DEC2</sub>	38	–	positive power supply voltage 2 decoupling; audio analog-to-digital converter circuitry
V <sub>ref(p)</sub>	39	–	positive reference voltage; audio analog-to-digital converter circuitry

## Digital TV Sound Processor (DTVSP)

TDA9870A

SYMBOL	PIN	I/O	DESCRIPTION
$V_{ref(n)}$	40	–	reference voltage ground; audio analog-to-digital converter circuitry
i.c.	41	–	internally connected; note 2
i.c.	42	–	internally connected; note 3
$V_{SSA2}$	43	supply	supply ground 2; audio analog-to-digital converter circuitry
i.c.	44	–	internally connected; note 3
i.c.	45	–	internally connected; note 2
$V_{ref2}$	46	–	reference voltage; audio analog-to-digital converter circuitry
SCOR1	47	O	SCART 1 right channel output
SCOL1	48	O	SCART 1 left channel output
$V_{SSD2}$	49	supply	supply ground 2; digital circuitry
$V_{SSA4}$	50	supply	supply ground 4; audio operational amplifier circuitry
SCOR2	51	O	SCART 2 right channel output
SCOL2	52	O	SCART 2 left channel output
$V_{ref3}$	53	–	reference voltage; audio digital-to-analog converter and operational amplifier circuitry
PCAPR	54	–	post-filter capacitor pin right channel, audio digital-to-analog converter
PCAPL	55	–	post-filter capacitor pin left channel, audio digital-to-analog converter
$V_{SSA3}$	56	supply	supply ground 3; audio digital-to-analog converter circuitry
AUXOR	57	O	headphone (Auxiliary) right channel output
AUXOL	58	O	headphone (Auxiliary) left channel output
$V_{DDA}$	59	supply	positive analog power supply voltage; analog circuitry
MOR	60	O	loudspeaker (Main) right channel output
MOL	61	O	loudspeaker (Main) left channel output
LOL	62	O	line output left channel
LOR	63	O	line output right channel
$V_{DDD2}$	64	supply	digital supply voltage 2; digital circuitry

**Notes**

1. Test pin, CMOS 3-state stage, pull-up resistor, can be connected to  $V_{SS}$ .
2. Test pin, CMOS level input, pull-up resistor, can be connected to  $V_{SS}$ .
3. Test pin, CMOS 3-state stage, can be connected to  $V_{SS}$ .



Digital TV Sound Processor (DTVSP)

TDA9870A

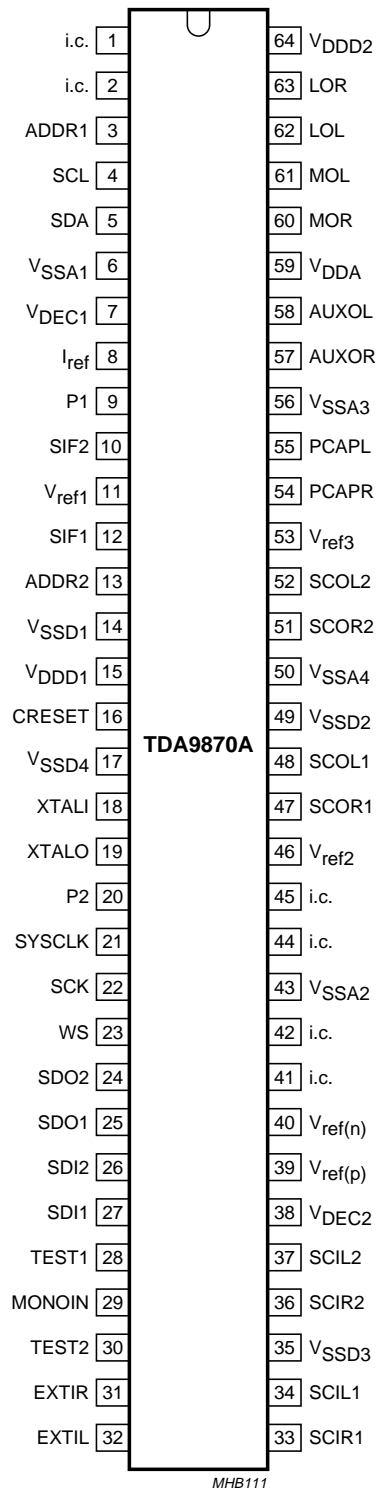

Fig.2 Pin configuration.

## Digital TV Sound Processor (DTVSP)

## TDA9870A

### 6 FUNCTIONAL DESCRIPTION

#### 6.1 Description of the demodulator and decoder section

##### 6.1.1 SIF INPUT

Two input pins are provided, SIF1 e.g. for terrestrial TV and SIF2 e.g. for a satellite tuner. For higher SIF signal levels the SIF input can be attenuated with an internally switchable  $-10$  dB resistor divider. As no specific filters are integrated, both inputs have the same specification giving flexibility in application. The selected signal is passed through an AGC circuit and then digitized by an 8-bit ADC operating at 24.576 MHz.

##### 6.1.2 AGC

The gain of the AGC amplifier is controlled from the ADC output by means of a digital control loop employing hysteresis. The AGC has a fast attack behaviour to prevent ADC overloads and a slow decay behaviour to prevent AGC oscillations. For AM demodulation the AGC must be switched off. When switched off, the control loop is reset and fixed gain settings can be chosen (see Table 14; subaddress 0).

The AGC can be controlled via the I<sup>2</sup>C-bus. Details can be found in the I<sup>2</sup>C-bus register definitions (see Chapter 10).

##### 6.1.3 MIXER

The digitized input signal is fed to the mixers, which mix one or both input sound carriers down to zero IF. A 24-bit control word for each carrier sets the required frequency. Access to the mixer control word registers is via the I<sup>2</sup>C-bus.

##### 6.1.4 FM AND AM DEMODULATION

An FM or AM input signal is fed via a band-limiting filter to a demodulator that can be used for either FM or AM demodulation. Apart from the standard (fixed) de-emphasis characteristic, an adaptive de-emphasis is available for encoded satellite programs. A stereo decoder recovers the left and right signal channels from the demodulated sound carriers. Both the European and Korean stereo systems are supported.

##### 6.1.5 FM IDENTIFICATION

The identification of the FM sound mode is performed by AM synchronous demodulation of the pilot signal and narrow-band detection of the identification frequencies. The result is available via the I<sup>2</sup>C-bus interface. A selection can be made via the I<sup>2</sup>C-bus for B/G, D/K and M standard and for three different modes that represent different trade-offs between speed and reliability of identification.

##### 6.1.6 CRYSTAL OSCILLATOR

The crystal oscillator (XO) is illustrated in Fig.8 (see Chapter 12). The circuitry of the XO is fully integrated, only the external 24.576 MHz crystal is needed.

##### 6.1.7 TEST PINS

Both test pins are active HIGH, in normal operation of the device they are connected to  $V_{SSD1}$ . Test functions are for manufacturing tests only and are not available to customers. Without external circuitry these pads are pulled down to LOW level with internal resistors.

##### 6.1.8 POWER FAIL DETECTOR

The power fail detector monitors the internal power supply for the digital part of the device. If the supply has temporarily been lower than the specified lower limit, the power-on reset bit POR, transmitter register subaddress 0 (see Section 10.4.1), will be set to HIGH. The CLR<sub>POR</sub> bit, slave register subaddress 1 (see Section 10.3.2), resets the power-on reset flip-flop to LOW. If this is detected, an initialization of the TDA9870A has to be performed to ensure reliable operation.

# Digital TV Sound Processor (DTVSP)

TDA9870A

## 6.2 Description of the DSP

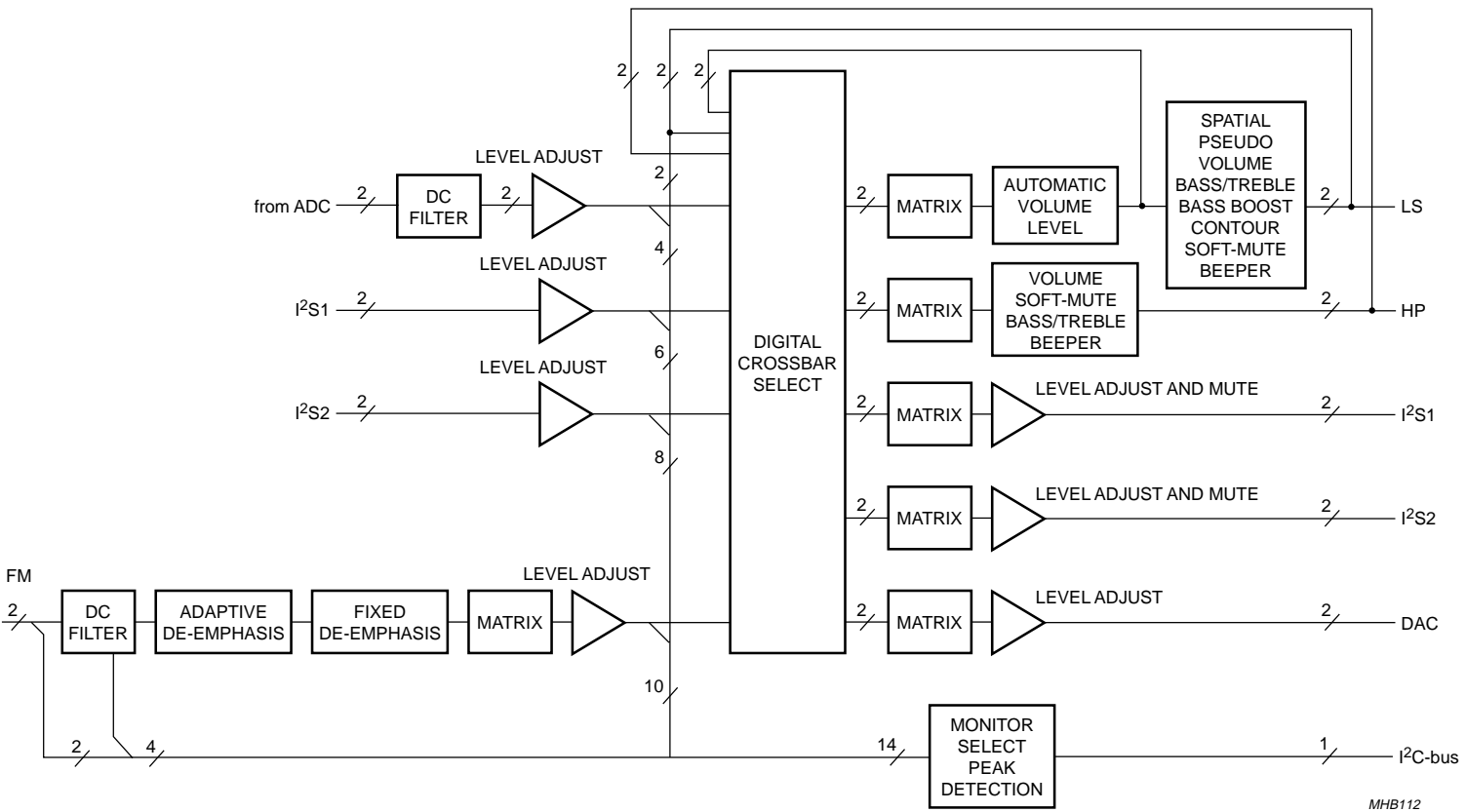

Fig.3 DSP data flow diagram.

## Digital TV Sound Processor (DTVSP)

## TDA9870A

### 6.2.1 LEVEL SCALING

All input channels to the digital crossbar switch (except for the loudspeaker feedback path) are equipped with a level adjust facility to change the signal level in a range of  $\pm 15$  dB. It is recommended to scale all input channels to be 15 dB below full scale ( $-15$  dB full scale) under nominal conditions.

### 6.2.2 FM (AM) PATH

A high-pass filter suppresses DC offsets from the FM demodulator, due to carrier frequency offsets, and supplies the monitor/peak function with DC values and an unfiltered signal, e.g. for the purpose of carrier detection.

The de-emphasis function offers fixed settings for the supported standards (50  $\mu$ s, 60  $\mu$ s and 75  $\mu$ s).

An adaptive de-emphasis is available for Wegener-Panda 1 encoded programs.

A matrix performs the dematrixing of the A2 stereo, dual and mono signals.

### 6.2.3 MONITOR

This function provides data words from a number of locations of the signal processing paths to the I<sup>2</sup>C-bus interface (2 data bytes). Signal sources include the FM demodulator outputs, most inputs to the digital crossbar switch and the outputs of the ADC. Source selection and data read-out is performed via the I<sup>2</sup>C-bus.

Optionally, the peak value can be measured instead of simply taking samples. The internally stored peak value is reset to zero when the data is read via the I<sup>2</sup>C-bus.

The monitor function may be used, for example, for signal level measurements or carrier detection.

### 6.2.4 LOUDSPEAKER (MAIN) CHANNEL

The matrix provides the following functions; forced mono, stereo, channel swap, channel 1, channel 2 and spatial effects.

There are fixed coefficient sets for spatial settings of 30%, 40% and 52%.

The Automatic Volume Level (AVL) function provides a constant output level of  $-23$  dB full scale for input levels between 0 and  $-29$  dB full scale. There are some fixed decay time constants to choose from, i.e. 2, 4 and 8 s.

Pseudo stereo is based on a phase shift in one channel via a 2nd-order all-pass filter. There are fixed coefficient sets to provide 90 degrees phase shift at frequencies of 150, 200 and 300 Hz.

Volume is controlled individually for each channel ranging from  $+24$  to  $-83$  dB with 1 dB resolution. There is also a mute position. For the purpose of a simple control software in the microcontroller, the decimal number that is sent as an I<sup>2</sup>C-bus data byte for volume control is identical to the volume setting in dBs (e.g. the I<sup>2</sup>C-bus data byte  $+10$  sets the new volume value to  $+10$  dB).

Balance can be realized by independent control of the left and right channel volume settings.

Contour is adjustable between 0 and  $+18$  dB with 1 dB resolution. This function is linked to the volume setting by means of microcontroller software.

Bass is adjustable between  $+15$  and  $-12$  dB with 1 dB resolution and treble is adjustable between  $\pm 12$  dB with 1 dB resolution.

For the purpose of a simple control software in the microcontroller, the decimal number that is sent as an I<sup>2</sup>C-bus data byte for contour, bass or treble is identical to the new contour, bass or treble setting in dBs (e.g. the I<sup>2</sup>C-bus data byte  $+8$  sets the new value to  $+8$  dB).

Extra bass boost is provided up to 20 dB with 2 dB resolution. The implemented coefficient set serves merely as an example on how to use this filter.

The beeper provides tones in a range from approximately 400 Hz to 30 kHz. The frequency can be selected via the I<sup>2</sup>C-bus. The beeper output signal is added to the loudspeaker and headphone channel signals. The beeper volume is adjustable with respect to full scale between 0 and  $-93$  dB with 3 dB resolution. The beeper is not effected by mute.

Soft mute provides a mute ability in addition to volume control with a well defined time (32 ms) after which the soft mute is completed. A smooth fading is achieved by a cosine masking.

### 6.2.5 HEADPHONE (AUXILIARY) CHANNEL

The matrix provides the following functions; forced mono, stereo, channel swap, channel 1 and channel 2 (or C and S in Dolby Surround Pro Logic mode).

Volume is controlled individually for each channel in a range from  $+24$  to  $-83$  dB with 1 dB resolution. There is also a mute position.

## Digital TV Sound Processor (DTVSP)

## TDA9870A

For the purpose of a simple control software in the microcontroller, the decimal number that is sent as an I<sup>2</sup>C-bus data byte for volume control is identical to the volume setting in dB (e.g. the I<sup>2</sup>C-bus data byte +10 sets the new volume value to +10 dB).

Balance can be realized by independent control of the left and right channel volume settings.

Bass is adjustable between +15 and -12 dB with 1 dB resolution and treble is adjustable between ±12 dB with 1 dB resolution.

For the purpose of a simple control software in the microcontroller, the decimal number that is sent as an I<sup>2</sup>C-bus data byte for bass or treble is identical to the new bass or treble setting in dB (e.g. the I<sup>2</sup>C-bus data byte +8 sets the new value to +8 dB).

The beeper provides tones in a range from approximately 400 Hz to 30 kHz. The frequency can be selected via the I<sup>2</sup>C-bus. The beeper output signal is added to the loudspeaker and headphone channel signals. The beeper volume is adjustable with respect to full scale between 0 and -93 dB with 3 dB resolution. The beeper is not effected by mute.

Soft mute provides a mute ability in addition to volume control with a well defined time (32 ms) after which the soft mute is completed. A smooth fading is achieved by a cosine masking.

### 6.2.6 FEATURE INTERFACE

The feature interface comprises two I<sup>2</sup>S-bus input/output ports and a system clock output. Each I<sup>2</sup>S-bus port is equipped with level adjust facilities that can change the signal level in a range of ±15 dB with 1 dB resolution. Outputs can be disabled to improve EMC performance.

The I<sup>2</sup>S-bus output matrix provides the following functions; forced mono, stereo, channel swap, channel 1 and channel 2.

One example of how the feature interface can be used in a TV set is to connect an external Dolby Surround Pro Logic DSP, such as the SAA7710, to the I<sup>2</sup>S-bus ports. Outputs must be enabled and a suitable master clock signal for the DSP can be taken from pin SYSCLK. A stereo signal from any source will be output on one of the I<sup>2</sup>S-bus serial data outputs and the four processed signal channels will be entered at both I<sup>2</sup>S-bus serial data inputs. Left and right could then be output to the power amplifiers via the Main channel, centre and surround via the Auxiliary channel.

### 6.2.7 CHANNEL FROM THE AUDIO ADC

The signal level at the output of the ADC can be adjusted in a range of ±15 dB with 1 dB resolution. The audio ADC itself is scaled to a gain of -6 dB.

### 6.2.8 CHANNEL TO THE ANALOG CROSSBAR PATH

Level adjust with control positions 0 dB, +3 dB, +6 dB and +9 dB.

### 6.2.9 DIGITAL CROSSBAR SWITCH (see Fig.6)

Input channels to the crossbar switch are from the audio ADC, I<sup>2</sup>S1, I<sup>2</sup>S2, FM path and from the loudspeaker channel path after matrix and AVL.

Output channels comprise loudspeaker, headphone, I<sup>2</sup>S1, I<sup>2</sup>S2 and the audio DACs for line output and SCART.

The I<sup>2</sup>S1 and I<sup>2</sup>S2 outputs also provide digital outputs from the loudspeaker and headphone channels, but without the beeper signals.

### 6.2.10 GENERAL

There are a number of functions that can provide signal gain, e.g. volume, bass and treble control. Great care has to be taken when using gain with large input signals in order not to exceed the maximum possible signal swing, which would cause severe signal distortion. The nominal signal level of the various signal sources to the digital crossbar switch should be 15 dB below digital full scale (-15 dB full scale). This means that a volume setting of, say, +15 dB would just produce a full scale output signal and not cause clipping, if the signal level is nominal.

Sending illegal data patterns via the I<sup>2</sup>C-bus will not cause any changes of the current setting for the volume, bass, treble, bass boost and level adjust functions.

### 6.2.11 EXPERT MODE

The TDA9870A provides a special expert mode that gives direct write access to the internal Coefficient RAM (CRAM) of the DSP. It can be used to create user-defined characteristics, such as a tone control with different corner frequencies or special boost/cut characteristics to correct the low-frequency loudspeaker and/or cabinet frequency responses by means of the bass boost filter. However, this mode must be used with great care.

More information on the functions of this device, such as the number of coefficients per function, their default values, memory addresses, etc., can be made available on request.

## Digital TV Sound Processor (DTVSP)

TDA9870A

## 6.2.12 OVERVIEW OF DSP FUNCTIONS

**Table 4** Overview of DSP functions

FUNCTION	EXPERT MODE	PARAMETER	VALUE	UNIT
Bass control for loudspeaker and headphone output	yes	control range	-12 to +15	dB
		resolution	1	dB
		resolution at frequency	40	Hz
Treble control for loudspeaker and headphone output	yes	control range	-12 to +12	dB
		resolution	1	dB
		resolution at frequency	14	kHz
Contour for loudspeaker output	yes	control range	0 to +18	dB
		resolution	1	dB
		resolution at frequency	40	Hz
Bass boost for loudspeaker output	yes	control range	0 to +20	dB
		resolution	2	dB
		resolution at frequency	20	Hz
		corner frequency	350	Hz
Volume control for each separate channel in loudspeaker and headphone output	no	control range	-83 to +24	dB
		resolution	1	dB
		mute position at step	10101100	
Soft-mute for loudspeaker and headphone output	no	processing time	32	ms
Spatial effects	yes	anti-phase crosstalk positions	30, 40 and 52	%
Pseudo stereo	yes	90 degree phase shift at frequency	150, 200 and 300	Hz
Beeper additional to the signal in the loudspeaker and headphone channel	yes	beep frequencies	see Section 10.3.38	
		control range	0 to -93	dB
		resolution	3	dB
		mute position at step	00100000	
Automatic Volume Level (AVL)	yes	step width	quasi continuously	
		AVL output level for an input level between 0 and -29 dB full scale	-23	dBFS
		attack time	10	ms
		decay time constant	2, 4 and 8	s
General	no	-3 dB lower corner frequency of DSP	10	Hz
		-1 dB bandwidth of DSP	14.5	kHz
Level adjust I <sup>2</sup> S1 and I <sup>2</sup> S2 inputs	yes	control range	-15 to +15	dB
		resolution	1	dB
Level adjust I <sup>2</sup> S1 and I <sup>2</sup> S2 outputs	yes	control range	-15 to +15	dB
		resolution	1	dB
		mute position at step	00010000	
Level adjust analog crossbar path	no	control positions	0, 3, 6 and 9	dB

Digital TV Sound Processor (DTVSP)

TDA9870A

FUNCTION	EXPERT MODE	PARAMETER	VALUE	UNIT
Level adjust audio ADC outputs	yes	control range	+15 to -15	dB
		resolution	1	dB
Level adjust FM path	yes	control range	+15 to -15	dB
		resolution	1	dB

6.3 Description of the analog audio section

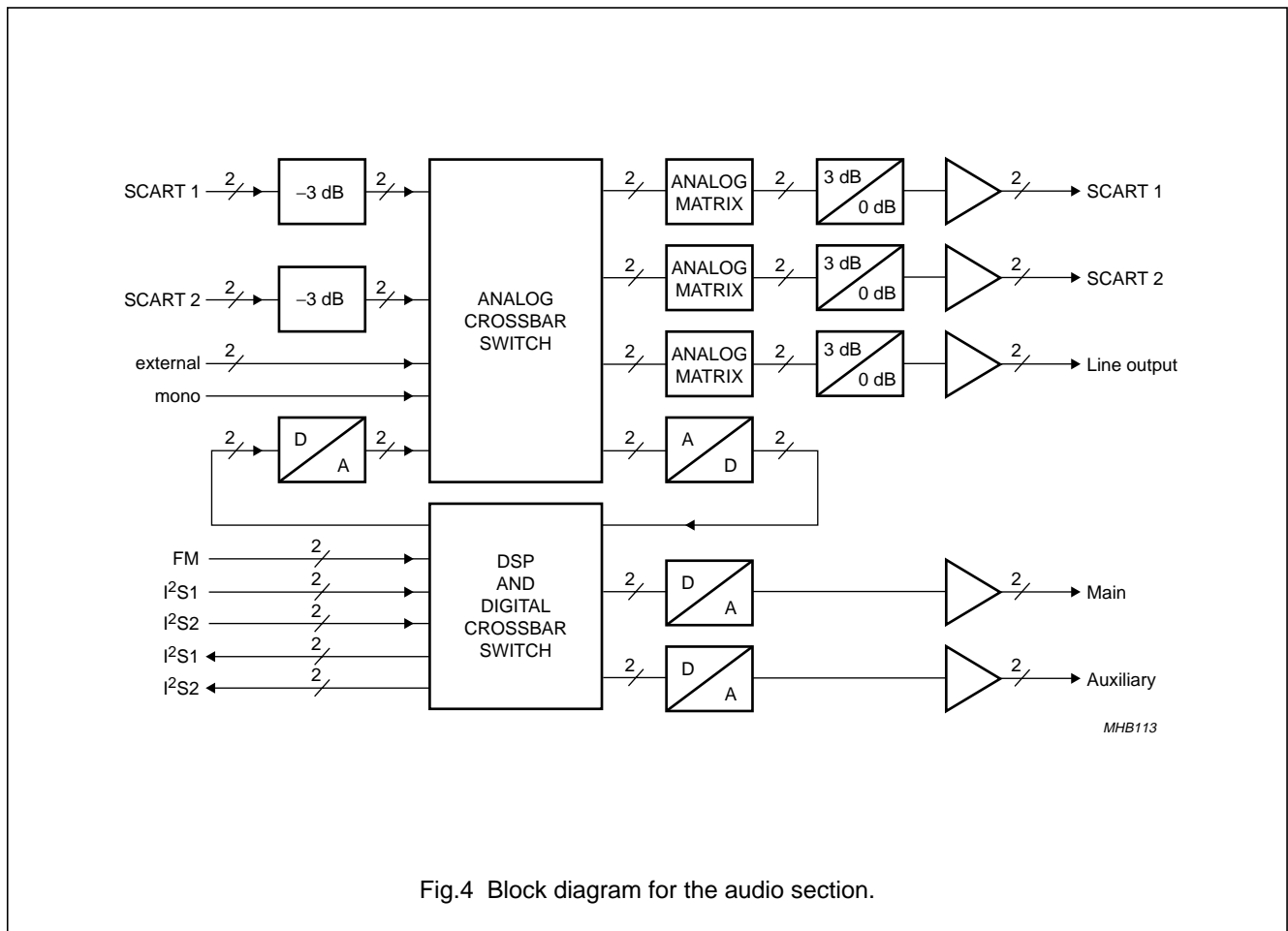

Fig.4 Block diagram for the audio section.

# Digital TV Sound Processor (DTVSP)

# TDA9870A

### 6.3.1 ANALOG CROSSBAR SWITCH AND ANALOG MATRIX (see also Fig.6)

There are a number of analog input and output ports with the TDA9870A. Analog source selector switches are employed to provide the desired analog signal routing capability. The analog signal routing is performed by the analog crossbar switch section. A dual audio ADC provides the connection to the DSP section and a dual audio DAC provides the connection from the DSP section to the analog crossbar switch. The digital signal routing is performed by a digital crossbar switch.

The basic signal routing philosophy of the TDA9870A is that each switch handles two signal channels at the same time, e.g. left and right, language A and B, directly at the source.

Each source selector switch is followed by an analog matrix to perform further selection tasks, such as putting a signal from one input channel, say language A, to both output channels or for swapping left and right channels. The analog matrix provides the functions given in Table 5 (see also Fig.5).

**Table 5** Analog matrix functions

MODE	MATRIX OUTPUT	
	LEFT OUTPUT	RIGHT OUTPUT
1	left input	right input
2	right input	left input
3	left input	left input
4	right input	right input

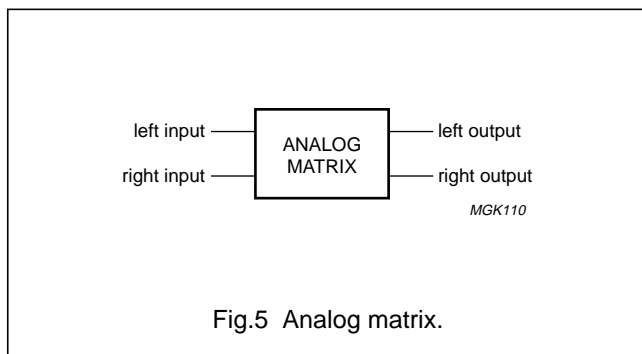

All switches and matrices are controlled via the I<sup>2</sup>C-bus.

### 6.3.2 SCART INPUTS

The SCART specification allows for a signal level of up to 2 V (RMS). Because of signal handling limitations, due to the 5 V supply voltage of the TDA9870A, it is necessary to have fixed 3 dB attenuators at the SCART inputs to obtain a 2 V input. This results in a -3 dB SCART-to-SCART copy gain. If 0 dB copy gain is preferred (with maximum 1.4 V input), there are 3 dB and 0 dB amplifiers at the outputs of SCART 1 and SCART 2 and at the line output.

The input attenuator is realized by an external series resistor in combination with the input impedance, both of which form a voltage divider. With this voltage divider the maximum SCART signal level of 2 V (RMS) is scaled down to 1.4 V (RMS) at the input pin.

### 6.3.3 EXTERNAL AND MONO INPUTS

The 3 dB input attenuators are not required for the external and mono inputs, because those signal levels are under control of the TV designer. The maximum allowed input level is 1.4 V (RMS). By adding external series resistors, the external inputs can be used as an additional SCART input.

### 6.3.4 SCART OUTPUTS

The SCART outputs employ amplifiers with two gain settings. The gain can be set to 3 dB or to 0 dB via the I<sup>2</sup>C-bus. The 3 dB position is needed to compensate for the 3 dB attenuation at the SCART inputs should SCART-to-SCART copies with 0 dB gain be preferred [under the condition of 1.4 V (RMS) maximum input level]. The 0 dB position is needed, for example, for an external-to-SCART copy with 0 dB gain.



---

## Digital TV Sound Processor (DTVSP)

## TDA9870A

---

### 6.3.5 LINE OUTPUT

The line output can provide an unprocessed copy of the audio signal in the loudspeaker channels. This can be either an external signal that comes from the dual audio ADC, or a signal from an internal digital audio source that comes from the dual audio DAC. The line output employs amplifiers with two gain settings. The 3 dB position is needed to compensate for the attenuation at the SCART inputs, while the 0 dB position is needed, for example, for non-attenuated external or internal digital signals (see Section 6.3.4).

### 6.3.6 LOUDSPEAKER (MAIN) AND HEADPHONE (AUXILIARY) OUTPUTS

Signals from any audio source can be applied to the loudspeaker and to the headphone output channels via the digital crossbar switch and the DSP.

### 6.3.7 DUAL AUDIO DAC

The TDA9870A contains three dual audio DACs, one for the connection from the DSP to the analog crossbar switch section and two for the loudspeaker and headphone outputs. Each of the three dual low-noise high-dynamic range DACs consists of two 15-bit DACs with current outputs, followed by a buffer operational amplifier. The audio DACs operate with four-fold oversampling and noise shaping.

### 6.3.8 DUAL AUDIO ADC

There is one dual audio ADC in the TDA9870A for the connection of the analog crossbar switch section to the DSP. The dual audio ADC consists of two bitstream 3rd-order sigma-delta audio ADCs and a high-order decimation filter.

### 6.3.9 STANDBY MODE

The standby mode (subaddress 1, bit 5) disables most functions and reduces power dissipation. The analog crossbar switch and the SCART section remains operational and can be controlled by the I<sup>2</sup>C-bus to support copying of analog signals from SCART-to-SCART.

Unused internal registers may lose their information in standby mode. Therefore, the device needs to be initialized on returning to normal operation. This can be accomplished in the same way as after a power-on reset.

### 6.3.10 SUPPLY GROUND

The different supply grounds  $V_{SSX}$  are internally connected via substrate. It is therefore recommended to connect all ground pins externally close to the pins by a copper plane.

Digital TV Sound Processor (DTVSP)

TDA9870A

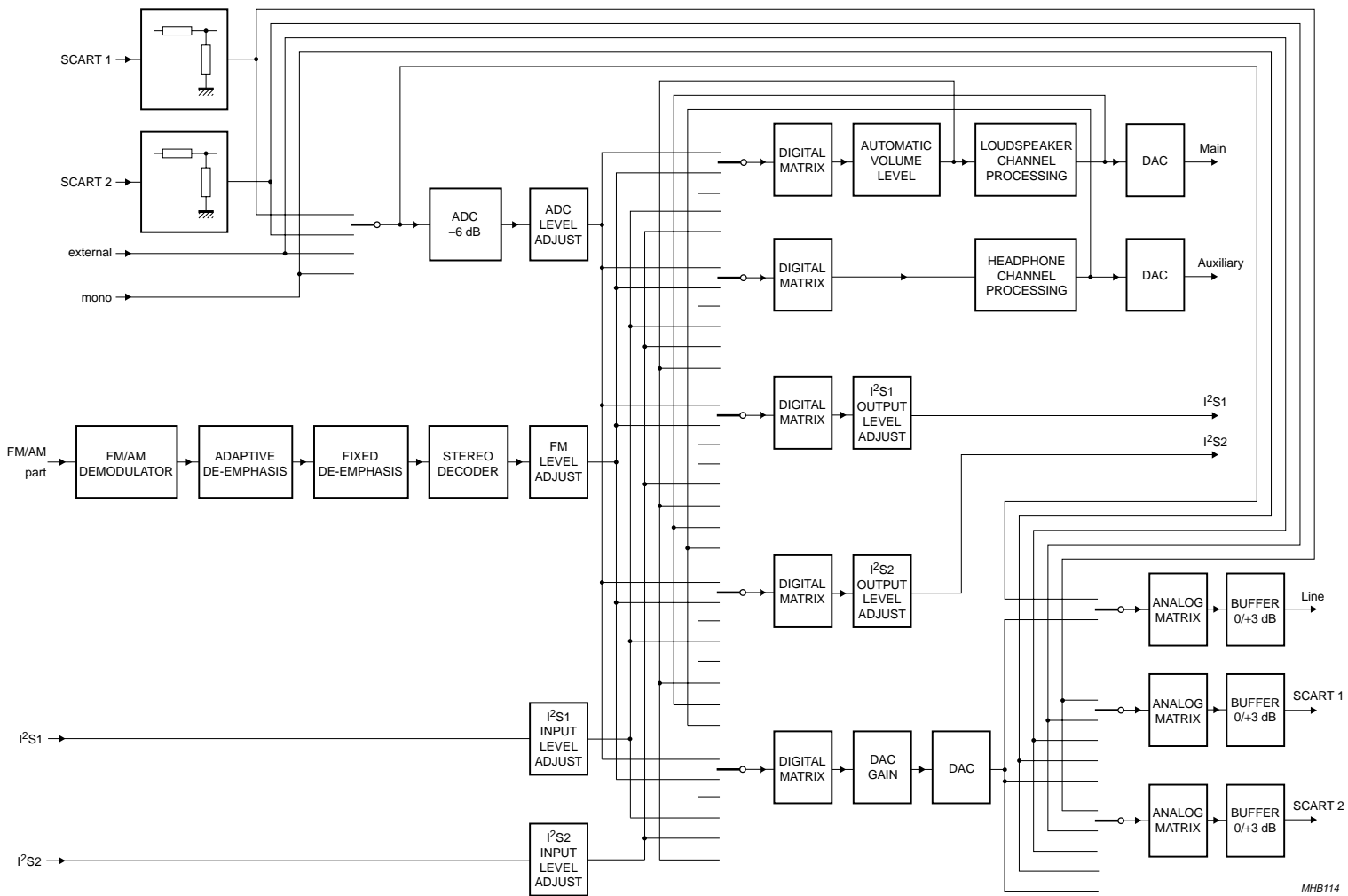

Fig.6 Audio signal flow diagram.

## Digital TV Sound Processor (DTVSP)

TDA9870A

**7 LIMITING VALUES**

In accordance with the Absolute Maximum Rating System (IEC 134).

SYMBOL	PARAMETER	CONDITIONS	MIN.	MAX.	UNIT
$V_{DD}$	DC supply voltage		-0.5	+6.0	V
$\Delta V_{DD}$	voltage differences between two $V_{DD}$ pins		-	550	mV
$I_{I/O(max)}$	maximum input/output voltage		-0.5	$V_{DD} + 0.5$	V
$I_{DDD}, I_{SSD}$	DC $V_{DD}$ or $V_{SS}$ current per digital supply pin		-	$\pm 180$	mA
$I_{lu(prot)}$	latch-up protection current		100	-	mA
$P_{tot}$	total power dissipation		-	1.2	W
$T_{stg}$	storage temperature		-55	+125	°C
$T_{amb}$	operating ambient temperature		-20	+70	°C
$V_{es}$	electrostatic handling	note 1	2000	-	V
		note 2	200	-	V

**Notes**

- Human body model: C = 100 pF; R = 1.5 k $\Omega$ .
- Machine model: C = 200 pF; L = 0.75  $\mu$ H; R = 0  $\Omega$ .

**8 THERMAL CHARACTERISTICS**

SYMBOL	PARAMETER	CONDITIONS	VALUE	UNIT
$R_{th(j-a)}$	thermal resistance from junction to ambient	in free air	40	K/W

## Digital TV Sound Processor (DTVSP)

## TDA9870A

**9 CHARACTERISTICS**

$V_{SIF(p-p)} = 300$  mV; AGCOFF = 0; AGCSLOW = 0; AGCLEV = 0; level and gain setting in accordance with note 3;  $V_{DD} = 5$  V;  $T_{amb} = 25$  °C; settings in accordance with B/G standard; FM deviation  $\pm 50$  kHz;  $f_{mod} = 1$  kHz; FM sound parameters in accordance with system A2; 1 k $\Omega$  measurement source resistance for AF inputs; unless otherwise specified; with external components of Fig.8.

SYMBOL	PARAMETER	CONDITIONS	MIN.	TYP.	MAX.	UNIT
<b>Supplies</b>						
$V_{DDD1}$	digital supply voltage 1		4.75	5.0	5.5	V
$V_{SSD1}$	digital supply ground 1	note 1	–	0.0	–	V
$I_{DDD1}$	digital supply current 1	$V_{DDD1} = 5.0$ V	53	68	83	mA
$V_{DDD2}$	digital supply voltage 2		4.75	5.0	5.5	V
$V_{SSD2}$	digital supply ground 2	note 1	–	0.0	–	V
$I_{DDD2}$	digital supply current 2	$V_{DDD2} = 5.0$ V; SYSCLOCK off	0.1	0.4	2	mA
$V_{SSD3}$	digital supply ground 3	note 1	–	0.0	–	V
$V_{SSD4}$	digital supply ground 4	note 1	–	0.0	–	V
$V_{DDA}$	analog supply voltage		4.75	5.0	5.5	V
$I_{DDA}$	analog supply current for DAC part	$V_{DDA} = 5.0$ V; digital silence	44	56	68	mA
$V_{SSA1}$	analog ground for analog front-end	note 1	–	0.0	–	V
$V_{SSA2}$	analog ground for audio ADC part	note 1	–	0.0	–	V
$V_{SSA3}$	analog ground for audio DAC part	note 1	–	0.0	–	V
$V_{SSA4}$	analog ground for SCART		–	0.0	–	V
<b>Demodulator supply decoupling and references</b>						
$V_{DEC1}$	analog supply decoupling voltage for demodulator part		3.0	3.3	3.6	V
$V_{ref1}$	analog reference voltage for demodulator part		–	2	–	V
$I_{ref1(sink)}$	$V_{ref1}$ sink current		–	200	–	$\mu$ A
<b>Audio supply decoupling and references</b>						
$V_{DEC2}$	analog supply decoupling voltage for audio ADC part		3.0	3.3	3.6	V
$V_{ref2}$	reference voltage for audio ADCs	referenced to $V_{DEC2}/V_{SSA2}$	–	50	–	%
$Z_{Vref2-VDEC2}$	impedance $V_{ref2}$ to $V_{DEC2}$		–	20	–	k $\Omega$
$Z_{Vref2-VSSA2}$	impedance $V_{ref2}$ to $V_{SSA2}$		–	20	–	k $\Omega$
$V_{ref3}$	reference voltage for audio DAC and operational amplifier	referenced to $V_{DDA}/V_{SSA3}$	–	50	–	%
$Z_{Vref3-VDDA}$	impedance $V_{ref3}$ to $V_{DDA}$		–	20	–	k $\Omega$
$Z_{Vref3-VSSA3}$	impedance $V_{ref3}$ to $V_{SSA3}$		–	20	–	k $\Omega$

## Digital TV Sound Processor (DTVSP)

## TDA9870A

SYMBOL	PARAMETER	CONDITIONS	MIN.	TYP.	MAX.	UNIT
<b>Power fail detector</b>						
$V_{th(pf)}$	power fail threshold level		–	3.9	–	V
<b>Digital inputs and outputs</b>						
INPUTS						
<i>CMOS level input, pull-down (pins TEST1 and TEST2)</i>						
$V_{IL}$	LOW-level input voltage		–	–	$0.3V_{DD}$	V
$V_{IH}$	HIGH-level input voltage		$0.7V_{DD}$	–	–	V
$C_i$	input capacitance		–	–	10	pF
$Z_i$	input impedance		–	50	–	k $\Omega$
<i>CMOS level input, hysteresis, pull-up (pin CRESET)</i>						
$V_{IL}$	LOW-level input voltage		–	–	$0.3V_{DD}$	V
$V_{IH}$	HIGH-level input voltage		$0.7V_{DD}$	–	–	V
$V_{hys}$	hysteresis voltage		–	1.3	–	V
$C_i$	input capacitance		–	–	10	pF
$Z_i$	input impedance		–	50	–	k $\Omega$
INPUTS/OUTPUTS						
<i>I<sup>2</sup>C-bus level input with Schmitt trigger, open-drain output stage, 400 kHz I<sup>2</sup>C operation and level (pins SCL and SDA)</i>						
$V_{IL}$	LOW-level input voltage		–	–	$0.3V_{DD}$	V
$V_{IH}$	HIGH-level input voltage		$0.7V_{DD}$	–	–	V
$V_{hys}$	hysteresis voltage		–	$0.05V_{DD}$	–	V
$I_{LI}$	input leakage current		–	–	$\pm 10$	$\mu$ A
$C_i$	input capacitance		–	–	10	pF
$V_{OL}$	LOW-level output voltage		–	–	0.6	V
$C_L$	load capacitance		–	–	400	pF
<i>TTL/CMOS level, 4 mA 3-state output stage, pull-up (pins ADDR1, ADDR2, P1, P2, SCK, WS, SDO1, SDO2, SDI1 and SDI2)</i>						
$V_{IL}$	LOW-level input voltage		–	–	0.8	V
$V_{IH}$	HIGH-level input voltage		2.0	–	–	V
$C_i$	input capacitance		–	–	10	pF
$V_{OL}$	LOW-level output voltage		–	–	0.4	V
$V_{OH}$	HIGH-level output voltage		2.4	–	–	V
$C_L$	load capacitance		–	–	100	pF
$Z_i$	input impedance		–	50	–	k $\Omega$

## Digital TV Sound Processor (DTVSP)

## TDA9870A

SYMBOL	PARAMETER	CONDITIONS	MIN.	TYP.	MAX.	UNIT
OUTPUTS						
<i>CMOS level output, 4 mA 3-state output stage, slew rate controlled (pin SYSCLK)</i>						
$V_{OL}$	LOW-level output voltage		–	–	$0.3V_{DD}$	V
$V_{OH}$	HIGH-level output voltage		$0.7V_{DD}$	–	–	V
$C_L$	load capacitance		–	–	100	pF
$I_{LIZ}$	3-state leakage current	$V_i = 0$ to $V_{DD}$	–	–	$\pm 10$	$\mu A$
<b>SIF1 and SIF2 analog inputs</b>						
$V_{SIF(max)(p-p)}$	maximum composite SIF input voltage for clipping (peak-to-peak value)	SIF input level adjust 0 dB	–	941	–	mV
		SIF input level adjust –10 dB	–	2976	–	mV
$V_{SIF(min)(p-p)}$	minimum composite SIF input voltage for lower limit of AGC (peak-to-peak value)	SIF input level adjust 0 dB	–	59	–	mV
		SIF input level adjust –10 dB	–	188	–	mV
AGC	AGC range		–	24	–	dB
$f_i$	input frequency		4	–	9.2	MHz
$R_i$	input resistance	AGCLEV = 0	10	–	–	k $\Omega$
$C_i$	input capacitance		–	7.5	11	pF
$\Delta f_{FM}$	FM deviation	B/G standard; THD < 1%	$\pm 100$	–	–	kHz
$\Delta f_{FM(FS)}$	FM deviation full-scale level	terrestrial FM; level adjust 0 dB	$\pm 150$	–	–	kHz
$C/N_{FM}$	FM carrier $C/N_c$ ratio	$N_{FM}$ bandwidth = 6 MHz; white noise for S/N = 40 dB; "CCIR468"; quasi peak	–	77	–	$\frac{dB_{FM}}{Hz}$
$\alpha_{ct}$	crosstalk attenuation SIF1 to SIF2	$f_i = 4$ to 9.2 MHz; note 2	50	–	–	dB
<b>Demodulator performance; note 3</b>						
THD + N	total harmonic distortion plus noise	from FM source to any output; $V_o = 1$ V (rms) with low-pass filter	–	0.3	0.5	%
S/N	signal-to-noise ratio	SC1 from FM source to any output; $V_o = 1$ V (rms); "CCIR468"; quasi peak	64	70	–	dB
		SC2 from FM source to any output; $V_o = 1$ V (rms); "CCIR468"; quasi peak	60	66	–	dB
$B_{-3dB}$	–3 dB bandwidth	from FM source to any output	14.5	15	–	kHz
$f_{res}$	frequency response 20 Hz to 14 kHz	from FM to any output; $f_{ref} = 1$ kHz; inclusive pre-emphasis and de-emphasis	–	$\pm 2$	–	dB
$\alpha_{cs(dual)}$	dual signal channel separation	note 4	65	70	–	dB

## Digital TV Sound Processor (DTVSP)

## TDA9870A

SYMBOL	PARAMETER	CONDITIONS	MIN.	TYP.	MAX.	UNIT
$\alpha_{cs(stereo)}$	stereo channel separation	note 5	40	45	–	dB
$\alpha_{AM}$	AM suppression for FM	AM: 1 kHz, 30% modulation; reference: 1 kHz, 50 kHz deviation	50	–	–	dB
$S/N_{AM}$	AM demodulation	SIF level 100 mV (RMS); 54% AM; 1 kHz AF; "CCIR468"; quasi peak	36	45	–	dB
IDENTIFICATION FOR FM SYSTEMS						
$mod_p$	pilot modulation for identification		25	50	75	%
$C/N_p$	pilot sideband C/N for identification start		–	27	–	dB Hz
$f_{ident}$	identification window	B/G stereo				
		slow mode	116.85	–	118.12	Hz
		medium mode	116.11	–	118.89	Hz
		fast mode	114.65	–	120.46	Hz
		B/G dual				
		slow mode	273.44	–	274.81	Hz
	medium mode	272.07	–	276.20	Hz	
	fast mode	270.73	–	277.60	Hz	
$t_{ident(on)}$	total identification time ON	slow mode	–	–	2	s
		medium mode	–	–	1	s
		fast mode	–	–	0.5	s
$t_{ident(off)}$	total identification time OFF	slow mode	–	–	2	s
		medium mode	–	–	1	s
		fast mode	–	–	0.5	s
<b>Analog audio inputs</b>						
MONO INPUT AND EXTERNAL INPUT						
$V_{i(nom)(rms)}$	nominal level input voltage (RMS value)	note 3	–	500	–	mV
$V_{i(clip)(rms)}$	clipping level input voltage (RMS value)	THD < 3%; note 6	1250	1400	–	mV
$R_i$	input resistance	note 6	28	35	42	k $\Omega$
SCART INPUTS						
$V_{i(nom)(rms)}$	nominal level input voltage at input pin (RMS value)	–3 dB divider with external 15 k $\Omega$ resistor; notes 3 and 7	–	350	–	mV
$V_{i(clip)(rms)}$	clipping level input voltage at input pin (RMS value)	–3 dB divider with external 15 k $\Omega$ resistor; THD < 3%; notes 6 and 7	1250	1400	–	mV
$R_i$	input resistance	note 6	28	35	42	k $\Omega$

## Digital TV Sound Processor (DTVSP)

## TDA9870A

SYMBOL	PARAMETER	CONDITIONS	MIN.	TYP.	MAX.	UNIT
<b>Analog audio outputs</b>						
LOUDSPEAKER (MAIN) AND HEADPHONE (AUXILIARY) OUTPUTS						
$V_{o(\text{clip})(\text{rms})}$	clipping level output voltage (RMS value)	THD < 3%	1250	1400	–	mV
$R_o$	output resistance		150	250	375	$\Omega$
$R_{L(\text{AC})}$	AC load resistance		10	–	–	$k\Omega$
$R_{L(\text{DC})}$	DC load resistance		10	–	–	$k\Omega$
$C_{oL}$	output load capacitance		–	10	12	nF
$V_{\text{offset}(\text{DC})}$	static DC offset voltage		–	30	70	mV
$\alpha_{\text{mute}}$	mute suppression	nominal input signal from any source; $f_i = 1$ kHz; note 3	80	–	–	dB
$G_{\text{ro}(\text{main,aux})}$	roll-off gain at 14.5 kHz for Main and Auxiliary channels	from any source	–3	–2	–	dB
$\text{PSRR}_{\text{main,aux}}$	power supply ripple rejection for Main and Auxiliary channels	$f_{\text{ripple}} = 70$ Hz; $V_{\text{ripple}} = 100$ mV (peak); $C_{V\text{ref}} = 47$ $\mu\text{F}$ ; signal from I <sup>2</sup> S-bus	40	45	–	dB
SCART OUTPUTS AND LINE OUTPUT						
$V_{o(\text{nom})(\text{rms})}$	nominal level output voltage (RMS value)	3 dB amplification; note 3	–	500	–	mV
$V_{o(\text{clip})(\text{rms})}$	clipping level output voltage (RMS value)	THD < 3%	1250	1400	–	mV
$R_o$	output resistance		150	250	375	$\Omega$
$R_{L(\text{AC})}$	AC load resistance		10	–	–	$k\Omega$
$R_{L(\text{DC})}$	DC load resistance		10	–	–	$k\Omega$
$C_{oL}$	output load capacitance		–	–	2.5	nF
$V_{\text{offset}(\text{DC})}$	static DC offset voltage	output amplifiers at 3 dB position	–	30	50	mV
$\alpha_{\text{mute}}$	mute suppression	nominal input signal from any source; $f_i = 1$ kHz; note 3	80	–	–	dB
B	bandwidth	from SCART, external and mono sources; –3 dB bandwidth	20	–	–	kHz
		from DSP sources; –3 dB bandwidth	14.5	–	–	kHz
PSRR	power supply ripple rejection	$f_{\text{ripple}} = 70$ Hz; $V_{\text{ripple}} = 100$ mV (peak); $C_{V\text{ref}} = 47$ $\mu\text{F}$ ; signal from I <sup>2</sup> S-bus	40	45	–	dB



## Digital TV Sound Processor (DTVSP)

## TDA9870A

SYMBOL	PARAMETER	CONDITIONS	MIN.	TYP.	MAX.	UNIT
<b>Audio performance</b>						
THD + N	total harmonic distortion plus noise	$V_i = V_o = 1$ V (RMS); $f_i = 1$ kHz; bandwidth 20 Hz to 15 kHz; note 8 from any analog audio input to I <sup>2</sup> S-bus	–	0.1	0.3	%
		from I <sup>2</sup> S-bus to any analog audio output	–	0.1	0.3	%
		SCART-to-SCART copy	–	0.1	0.3	%
		SCART-to-Main copy	–	0.2	0.5	%
S/N	signal-to-noise ratio	reference voltage $V_o = 1.4$ V (RMS); $f_i = 1$ kHz; "CCIR468"; quasi peak; note 8 from any analog audio input to I <sup>2</sup> S-bus	73	77	–	dB
		from I <sup>2</sup> S-bus to any analog audio output	78	85	–	dB
		SCART-to-SCART copy	78	85	–	dB
		SCART-to-Main copy	73	77	–	dB
$\alpha_{ct}$	crosstalk attenuation	between any analog input pairs; $f_i = 1$ kHz	70	–	–	dB
		between any analog output pairs; $f_i = 10$ kHz	65	–	–	dB
$\alpha_{cs}$	channel separation	between left and right of any input pair	65	–	–	dB
		between left and right of any output pair	60	–	–	dB
$G_A$	gain from SCART-to-SCART with –3 dB input voltage divider	output amplifier in 3 dB position; $R_{ext} = 15$ k $\Omega \pm 10\%$	–1.5	0	+1.1	dB
		output amplifier in 0 dB position; $R_{ext} = 15$ k $\Omega \pm 10\%$	–4.5	–3.0	–1.9	dB

## Digital TV Sound Processor (DTVSP)

## TDA9870A

SYMBOL	PARAMETER	CONDITIONS	MIN.	TYP.	MAX.	UNIT
<b>Crystal specification (fundamental mode)</b>						
$f_{\text{xtal}}$	crystal frequency		–	24.576	–	MHz
$C_L$	load capacitance		–	20	–	pF
$C_1$	series capacitance		–	20	–	fF
$C_0$	parallel capacitance		–	–	7	pF
$\Phi_{\text{pull}}$	pulling sensitivity	$C_L$ changed from 18 to 16 pF	–	25	–	$\frac{10^{-6}}{\text{pF}}$
$R_R$	equivalent series resistance	at nominal frequency	–	–	30	$\Omega$
$R_N$	equivalent series resistance of unwanted mode		$2R_R$	–	–	$\Omega$
$\Delta T$	temperature range		–20	+25	+70	$^{\circ}\text{C}$
$X_J$	adjustment tolerance		–	–	$\pm 30$	$10^{-6}$
$X_D$	drift	across temperature range	–	–	$\pm 30$	$10^{-6}$
$X_A$	ageing		–	–	$\pm 5$	$\frac{10^{-6}}{\text{year}}$

**Notes**

- All analog and digital supply ground pins are connected internally.
- Set demodulator to AM mode. Apply an AM carrier (with 1 kHz and 100%) to one channel. Check AGC step. Switch AGC off and set AGC to the gain step found. Measure the 1 kHz signal level of this channel and take it as a reference. Switch to the other SIF input to which no signal is connected and which is terminated with 50  $\Omega$ . Measure now the 1 kHz crosstalk signal level. The SIF source resistance should be low (50  $\Omega$ ).
- Definitions of levels and level setting:  
The full-scale level for analog audio signals is  $V_{FS} = 1.4$  V (RMS). The nominal level at the digital crossbar switch is defined at –15 dB (full-scale). Nominal audio input levels:  
external, mono: 500 mV (RMS); –9 dB (full-scale).  
See also Tables 6 and 7.
- FM source; in dual mode only A (respectively B) signal modulated; measured at B (respectively A) channel output;  $V_o = 1$  V (RMS) of modulated channel.
- FM source; in stereo mode only L (respectively R) signal modulated; measured at R (respectively L) channel output;  $V_o = 1$  V (RMS) of modulated channel. The stereo channel separation may be limited by adjustment tolerances of the transmitter.
- If the supply voltage for the TDA9870A is switched off, because of the ESD protection circuitry, all audio input pins are short-circuited. To avoid a short-circuit at the SCART inputs a 15 k $\Omega$  resistor (–3 dB divider) has to be used.
- The SCART specification allows a signal level of up to 2 V (RMS). Because of signal handling limitations due to the 5 V supply voltage for the TDA9870A, there is a need for fixed 3 dB attenuators at the SCART inputs. To achieve SCART-to-SCART copies with 0 dB gain, there are 3 dB and 0 dB amplifiers at the outputs of SCART 1 and SCART 2 and at the line output. The attenuator is realized by an internal resistor that works together with an external series resistor as a voltage divider. With this voltage divider the maximum SCART input signal level of 2 V (RMS) is scaled down to 1.4 V (RMS) at the input pin. To avoid clipping, the 3 dB gain must not be used if the SCART input signal is larger than 1.4 V (RMS).
- ADC level adjust = 6 dB, all other level adjusts = 0 dB, if external –3 dB divider is used set output buffer gain to 3 dB, tone control to 0 dB, AVL off and volume control to 0 dB.

## Digital TV Sound Processor (DTVSP)

TDA9870A

**Table 6** FM level setting

0 dB (full-scale) = 1.4 V (RMS); note 1.

2 CHANNEL FM STANDARD	TRANSMITTER NOMINAL MODULATION DEPTH	NOMINAL LEVEL AT DEMODULATOR OUTPUT (FULL-SCALE)	CARRIER #1 FREQUENCY	CARRIER #2		DE-EMPHASIS OF CARRIER #1 AND CARRIER #2	FM LEVEL ADJUST SETTING OF CARRIER #1 AND CARRIER #2
				FREQUENCY	IDENT		
M	15 kHz deviation	-24 dB; note 2	4.5 MHz	4.724 MHz	on	75 $\mu$ s	9 dB
B/G	27 kHz deviation	-19 dB	5.5 MHz	5.742 MHz	on	50 $\mu$ s	4 dB
D/K	27 kHz deviation	-19 dB	6.5 MHz	6.742 MHz	on	50 $\mu$ s	4 dB
	27 kHz deviation	-19 dB	6.5 MHz	6.25 MHz	on	50 $\mu$ s	4 dB
	27 kHz deviation	-19 dB	6.5 MHz	5.742 MHz	on	50 $\mu$ s	4 dB

**Notes**

1. Nominal level at digital crossbar is defined at -15 dB (full-scale). DAC gain setting 6 dB. Output buffer setting 0 dB. Nominal SCART output level 500 mV (RMS).
2. For stereo signals the output level is 6 dB lower. The level adjust has to be increased by 6 dB.

**Table 7** Level setting SAT FM

0 dB (full-scale) = 1.4 V (RMS).

SOURCE	TRANSMITTER MAXIMUM MODULATION DEPTH	NOMINAL LEVEL AT DEMODULATOR OUTPUT (FULL-SCALE)	FM LEVEL ADJUST SETTING	MAXIMUM LEVEL AT CROSSBAR (FULL-SCALE)	DAC GAIN SETTING	OUTPUT BUFFER	NOMINAL SCART OUTPUT VOLTAGE
SAT FM, stereo	50 kHz deviation	-13 dB	4 dB	-9 dB	6 dB	0 dB	1 V (RMS)
SAT FM, mono	85 kHz deviation	-9 dB	0 dB				

## Digital TV Sound Processor (DTVSP)

## TDA9870A

**10 I<sup>2</sup>C-BUS CONTROL****10.1 Introduction**

The TDA9870A is fully controlled via the I<sup>2</sup>C-bus. Control is exercised by writing data to one or more internal registers. Status information can be read from an array of registers to enable the controlling microcontroller to determine whether any action is required.

The device has an I<sup>2</sup>C-bus slave transceiver, in accordance with the fast-mode specification, with a maximum speed of 400 kbits/s. Information concerning the I<sup>2</sup>C-bus can be found in brochure "*I<sup>2</sup>C-bus and how to use it*" (order number 9398 393 40011). To avoid conflicts in a real application with other ICs providing similar or complementary functions, there are four possible slave addresses available which can be selected by pins ADDR1 and ADDR2 (see Table 8).

**Table 8** Possible slave addresses

ADDR2	ADDR1	SLAVE ADDRESS A6 TO A0
0	0	1 0 1 1 0 0 0
0	1	1 0 1 1 0 0 1
1	0	1 0 1 1 0 1 0
1	1	1 0 1 1 0 1 1

The I<sup>2</sup>C-bus interface remains operational in the standby mode of the TDA9870A to allow control of the analog source selectors with regard to SCART-to-SCART copying.

The device will not respond to a 'general call' on the I<sup>2</sup>C-bus, i.e. when a slave address of 0000000 is sent by a master.

The data transmission between the microcontroller and the other I<sup>2</sup>C-bus controlled ICs is not disturbed when the supply voltage of the TDA9870A is not connected.

**10.2 Power-up state**

At power-up the device is in the following state:

- All outputs muted
- No sound carrier frequency loaded
- General purpose I/O pins ready for input (HIGH)
- Input SIF1 selected with:
  - AGC on
  - Small hysteresis
  - SIF input level shift 0 dB.
- Demodulators for both sound carriers set to FM with:
  - Identification for B/G, D/K, response time 1 s
  - Level adjust set to 0 dB
  - De-emphasis 50 µs
  - Matrix set to mono.
- Main channel set to FM input with:
  - Spatial off
  - Pseudo off
  - AVL off
  - Volume mute
  - Bass flat
  - Treble flat
  - Contour off
  - Bass boost flat.
- Auxiliary channel set to FM input with:
  - Volume mute
  - Bass flat
  - Treble flat.
- Feature interface all outputs off
- Beeper off
- Monitoring of carrier 1 FM demodulator DC output.

After power-up a device initialization has to be performed via the I<sup>2</sup>C-bus to put the TDA9870A into the proper mode of operation, in accordance with the desired TV standard, audio control settings, etc.

## Digital TV Sound Processor (DTVSP)

## TDA9870A

**10.3 Slave receiver mode**

As a slave receiver, the TDA9870A provides 46 registers for storing commands and data. These registers are accessed via so-called subaddresses. A subaddress can be thought of as a pointer to an internal memory location.

**Table 9** I<sup>2</sup>C-bus; slave address, subaddress and data format

S	SLAVE ADDRESS	0	ACK	SUBADDRESS	ACK	DATA	ACK	P
---	---------------	---	-----	------------	-----	------	-----	---

**Table 10** Explanation of Table 9

BIT	FUNCTION
S	START condition
SLAVE ADDRESS	7-bit device address
0	data direction bit (write to device)
ACK	acknowledge by slave
SUBADDRESS	address of register to write to
DATA	data byte to be written into register
P	STOP condition

It is allowed to send more than one data byte per transmission to the TDA9870A. In this event, the subaddress is automatically incremented after each data byte, resulting in storing the sequence of data bytes at successive register locations, starting at SUBADDRESS. A transmission can start at any valid subaddress. Each byte is acknowledged with ACK (acknowledge).

There is no 'wrap-around' of subaddresses.

Commands and data are processed as soon as they have been completely received. Functions requiring more than one byte will, thus, be executed only after all bytes for that function have been received. If the transmission is terminated (STOP condition) before all bytes have been received, the incomplete data for that function is ignored.

**Table 11** Format for a transmission employing auto-increment of subaddresses

S	SLAVE ADDRESS	0	ACK	SUBADDRESS	ACK	DATA BYTE A <sup>(1)</sup>	DATA	ACK	P
---	---------------	---	-----	------------	-----	----------------------------	------	-----	---

**Note**

1. n data bytes with auto-increment of subaddresses.

Data patterns sent to the various subaddresses are not checked for being illegal or not at that address, except for the functions of volume, bass, treble control, bass boost and level adjust.

Detection of a STOP condition without a preceding acknowledge bit is regarded as a bus error. The last operation will not then be executed.

## Digital TV Sound Processor (DTVSP)

## TDA9870A

Table 12 Overview of the slave receiver registers

SUBADDRESS (DECIMAL)	DATA								FUNCTION
	MSB				LSB				
0	0	0	s	g	g	g	g	g	AGC level shift, AGC gain selection
1	c	c	c	c	c	c	c	c	general configuration
2	p	0	0	m	m	s	s	s	monitor select, peak detector on/off
3	f	f	f	f	f	f	f	f	carrier 1 frequency; MS part
4	f	f	f	f	f	f	f	f	carrier 1 frequency
5	f	f	f	f	f	f	f	f	carrier 1 frequency; LS part
6	f	f	f	f	f	f	f	f	carrier 2 frequency; MS part
7	f	f	f	f	f	f	f	f	carrier 2 frequency
8	f	f	f	f	f	f	f	f	carrier 2 frequency; LS part
9	c	c	c	c	c	c	c	c	demodulator configuration
10	d	d	d	d	d	d	d	d	FM de-emphasis
11	0	0	0	0	0	m	m	m	FM matrix
12	0	0	0	l	l	l	l	l	channel 1 output level adjust
13	0	0	0	l	l	l	l	l	channel 2 output level adjust
14	0	0	0	0	0	0	0	0	set to logic 0; note 1
15	0	0	0	0	0	0	0	0	set to logic 0; note 1
16	0	0	0	0	0	0	0	0	set to logic 0; note 1
17	0	0	0	0	0	0	0	0	set to logic 0; note 1
18	m	m	m	m	m	m	m	m	audio mute control
19	g	m	m	m	g	s	s	s	DAC output select
20	0	g	m	m	0	s	s	s	SCART 1 output select
21	0	g	m	m	0	s	s	s	SCART 2 output select
22	0	g	m	m	0	0	0	s	line output select
23	s	s	s	l	l	l	l	l	ADC output select
24	0	m	m	m	0	s	s	s	Main channel select
25	0	0	s	s	p	p	a	a	audio effects (AVL, pseudo, spatial)
26	v	v	v	v	v	v	v	v	volume control, Main left
27	v	v	v	v	v	v	v	v	volume control, Main right
28	0	0	0	c	c	c	c	c	contour control, Main
29	0	0	0	b	b	b	b	b	bass control, Main
30	0	0	0	t	t	t	t	t	treble control, Main
31	0	m	m	m	0	s	s	s	Auxiliary channel select
32	v	v	v	v	v	v	v	v	volume control, Auxiliary left
33	v	v	v	v	v	v	v	v	volume control, Auxiliary right
34	0	0	0	b	b	b	b	b	bass control, Auxiliary
35	0	0	0	t	t	t	t	t	treble control, Auxiliary
36	0	0	0	c	c	c	c	c	feature interface configuration
37	0	m	m	m	0	s	s	s	I <sup>2</sup> S1 output select

## Digital TV Sound Processor (DTVSP)

TDA9870A

SUBADDRESS (DECIMAL)	DATA								FUNCTION
	MSB				LSB				
38	0	0	0	i	i	i	i	i	I <sup>2</sup> S1 input level adjust
39	0	0	0	o	o	o	o	o	I <sup>2</sup> S1 output level adjust
40	0	m	m	m	0	s	s	s	I <sup>2</sup> S2 output select
41	0	0	0	i	i	i	i	i	I <sup>2</sup> S2 input level adjust
42	0	0	0	o	o	o	o	o	I <sup>2</sup> S2 output level adjust
43	0	0	0	0	0	f	f	f	beeper frequency
44	0	0	v	v	v	v	v	v	beeper volume, Main and Auxiliary
45	b	b	b	b	b	b	b	b	bass boost, Main left and right

**Note**

1. These bits have not been assigned to a function.

The following sub-sections provide a detailed description of the slave receiver registers:

### 10.3.1 AGC GAIN REGISTER

#### 10.3.1.1 Description

If the automatic gain control function is switched off in the general configuration register, the contents of this register will define a fixed gain of the AGC stage. The input voltages given are meant to generate a full scale output from the SIF ADC. If automatic gain control is on, the AGCGAIN setting is ignored. After switching off the automatic gain control function, the latest gain control setting is copied to the AGC gain register. If the AGC input level shift bit AGCLEV is set to HIGH the input signal is scaled with –10 dB. The AGCLEV bit is also active if the automatic gain function is enabled.

It should be noted that the input voltages should be considered as approximate target values.

**Table 13** Description of the AGC gain register

BIT	NAME	DESCRIPTION
7 (MSB)	–	set to logic 0
6	–	set to logic 0
5	AGCLEV	If the AGC input level shift bit AGCLEV is set to HIGH the input signal is scaled with –10 dB. The AGCLEV bit is also active if the automatic gain function is enabled.
4	AGCGAIN	If the automatic gain control function is switched off in the general configuration register, the contents of this register will define a fixed gain of the AGC stage.
3		
2		
1		
0 (LSB)		

## Digital TV Sound Processor (DTVSP)

## TDA9870A

## 10.3.1.2 Definition

Table 14 Subaddress 0

MSB							LSB	AGC GAIN (dB)	SIF INPUT VOLTAGE (mV (p-p))
B7	B6	B5	B4	B3	B2	B1	B0		
0	0	0/1	1	1	1	1	1	0.0	941/2976
0	0	0/1	1	1	1	1	0	0.8	861/2723
0	0	0/1	1	1	1	0	1	1.5	788/2490
0	0	0/1	1	1	1	0	0	2.3	720/2278
0	0	0/1	1	1	0	1	1	3.1	659/2084
0	0	0/1	1	1	0	1	0	3.9	603/1906
0	0	0/1	1	1	0	0	1	4.6	551/1744
0	0	0/1	1	1	0	0	0	5.4	504/1595
0	0	0/1	1	0	1	1	1	6.2	461/1459
0	0	0/1	1	0	1	1	0	7.0	422/1334
0	0	0/1	1	0	1	0	1	7.7	386/1221
0	0	0/1	1	0	1	0	0	8.5	353/1117
0	0	0/1	1	0	0	1	1	9.3	323/1021
0	0	0/1	1	0	0	1	0	10.1	295/934
0	0	0/1	1	0	0	0	1	10.8	270/855
0	0	0/1	1	0	0	0	0	11.6	247/782
0	0	0/1	0	1	1	1	1	12.4	226/715
0	0	0/1	0	1	1	1	0	13.2	207/654
0	0	0/1	0	1	1	0	1	13.9	189/598
0	0	0/1	0	1	1	0	0	14.7	173/547
0	0	0/1	0	1	0	1	1	15.5	158/501
0	0	0/1	0	1	0	1	0	16.3	145/458
0	0	0/1	0	1	0	0	1	17.0	132/419
0	0	0/1	0	1	0	0	0	17.8	121/383
0	0	0/1	0	0	1	1	1	18.6	111/350
0	0	0/1	0	0	1	1	0	19.4	101/321
0	0	0/1	0	0	1	0	1	20.1	93/293
0	0	0/1	0	0	1	0	0	20.9	85/268
0	0	0/1	0	0	0	1	1	21.7	78/245
0	0	0/1	0	0	0	1	0	22.5	71/224
0	0	0/1	0	0	0	0	1	23.2	65/205
0	0	0/1	0	0	0	0	0	24.0	59/188 (note 1)

**Note**

1. The default setting at power-up is 00000000.



## Digital TV Sound Processor (DTVSP)

## TDA9870A

## 10.3.2 GENERAL CONFIGURATION REGISTER

## 10.3.2.1 Description

Table 15 Description of Table 16

NAME	HIGH/LOW	FUNCTION
SIFSEL	HIGH	Selects pin SIF2 for input (recommended for satellite tuner).
	LOW	Pin SIF1 (terrestrial TV) is selected.
AGCOFF	HIGH	Forces the AGC block to a fixed gain as defined in the AGC gain register.
	LOW	The automatic gain control function is enabled and the contents of the AGC gain register is ignored.
AGCSLOW	HIGH	A longer decay time is selected for input signals with strong video modulation (intercarrier). This bit only has an effect when bit AGCOFF = 0.
	LOW	Selects normal attack and decay times for the AGC.
CLRPOR	HIGH	Resets the power fail detector to LOW.
	LOW	This bit is automatically reset to LOW after bit POR in the device status register has been reset.
INIT	HIGH	Causes initialization of TDA9870A to its default settings. This has the same effect as a power-on reset. If there is a conflict between the default settings and any bit set HIGH in this register, the bits of this register have priority over the corresponding default setting.
	LOW	This bit is automatically reset to LOW after initialization. When set LOW, the TDA9870A is in its normal mode of operation.
STDBY	HIGH	Puts the TDA9870A into the standby mode. Most functions are disabled and power dissipation is somewhat reduced, but the analog selectors/matrices remain operational to support analog copying from SCART-to-SCART and vice versa.
	LOW	The TDA9870A is in its normal mode of operation. On return from standby mode, the device is in its power-on reset mode and needs to be re-initialized.
P1OUT, P2OUT	–	These bits control the general purpose input/output pins. The contents of these bits is written directly to the corresponding pins. If input is desired, the bits must be set HIGH to allow the pins to be pulled LOW externally. Input from the pins is reflected in the device status register (see Section 10.4, subaddress 0). P1OUT is recommended to be used for switching an SIF trap for the adjacent picture carrier in designs that employ such a trap.

## 10.3.2.2 Definition

Table 16 Subaddress 1 (note 1)

BIT	NAME	DESCRIPTION
7 (MSB)	P2OUT	general purpose I/O pin 2
6	P1OUT	general purpose I/O pin 1
5	STDBY	standby mode on/off
4	INIT	initialize to defaults (as reset)
3	CLRPOR	clear power-on reset flip-flop
2	AGCSLOW	AGC decay time
1	AGCOFF	AGC on/off
0 (LSB)	SIFSEL	SIF input select

## Note

1. The default setting at power-up is 11000000.

# Digital TV Sound Processor (DTVSP)

# TDA9870A

## 10.3.3 MONITOR SELECT REGISTER

### 10.3.3.1 Description

This register is used to define the signal source, the level of which is to be monitored, and if the peak level is to be monitored. Peak level refers to the magnitude of the maximum excursion of a signal. Data can be read-out in the I<sup>2</sup>C-bus slave transmitter mode (see Section 10.4, subaddresses 5 and 6).

Audio magnitude/phase is related to the FM demodulator output. Phase information is provided, when it operates in FM mode, while magnitude is supplied in AM mode.

**Table 17** Description of bit PEAKMON

NAME	HIGH/LOW	FUNCTION
PEAKMON	HIGH	selects the peak level of a source to be monitored
	LOW	the last sample will be supplied

### 10.3.3.2 Definition

**Table 18** Subaddress 2 (note 1)

MSB						LSB	
B7	B6	B5	B4	B3	B2	B1	B0
PEAKMON	0	0	see Table 20		see Table 19		

**Note**

- The default setting at power-up is 00000000.

**Table 19** Signal source (note 1)

B2	B1	B0	SIGNAL SOURCE
0	0	0	DC output of FM demodulator
0	0	1	audio magnitude/phase, FM demodulator output
0	1	0	crossbar input from FM/AM channel
0	1	1	don't care
1	0	0	crossbar input from I <sup>2</sup> S1 channel
1	0	1	crossbar input from I <sup>2</sup> S2 channel
1	1	0	crossbar input from audio ADC channel
1	1	1	input to Main channel DAC (without beeper)

**Note**

- The term 'crossbar' refers to the digital selector, where level-adjusted signals from various sources are available.

Digital TV Sound Processor (DTVSP)

TDA9870A

**Table 20** Monitor output

B4	B3	MONITOR OUTPUT
0	0	$\frac{L \text{ input} + R \text{ input}}{2}$
0	1	L input (channel 1, respectively)
1	0	R input (channel 2, respectively)

10.3.3.3 Note

By reading out level read-out registers (subaddresses 5 and 6, see Section 10.4), the current peak level will be reset.

10.3.4 CARRIER 1 FREQUENCY REGISTER

10.3.4.1 Description

The three bytes together constitute a 24-bit frequency control word to represent the sound carrier (i.e. mixer) frequency in accordance with the following formula:

$$\text{data} = \frac{f_{\text{mix}}}{f_{\text{clk}}} \times 2^{24}$$

Where:

- data = 24-bit frequency control word.
- $f_{\text{mix}}$  = desired sound carrier frequency.
- $f_{\text{clk}}$  = 12.288 MHz (clock frequency of mixer).
- $2^{24}$  = 16777216 (number of steps in a 24-bit word size).

Example: A 5.5 MHz sound carrier frequency will be generated by sending the following sequence of data bytes to the TDA9870A (data = 7509333 in decimal notation or 729555 in HEX): 01110010 10010101 01010101.

As three bytes are required to define a carrier frequency, execution of this command starts only after all bytes have been received. If an error occurs, e.g. a premature STOP condition, partial data for this function is ignored.

The default setting at power-up is 00000000 for all three bytes.

10.3.4.2 Definition

Most significant part at subaddress 3.

**Table 21** Subaddresses 3 to 5

BIT	SUBADDRESSES
7 (MSB)	3
6	
5	
4	
3	
2	
1	
0	
7	4
6	
5	
4	
3	
2	
1	
0	
7	5
6	
5	
4	
3	
2	
1	
0 (LSB)	

10.3.5 CARRIER 2 FREQUENCY REGISTER

10.3.5.1 Description

Same as for sound carrier 1.

If the carrier 2 frequency register is used, it will be for the second FM sound carrier of a terrestrial or satellite FM program.

## Digital TV Sound Processor (DTVSP)

TDA9870A

## 10.3.5.2 Definition

Subaddresses 6 to 8.

Same as for sound carrier 1, except for subaddresses used.

## 10.3.6 DEMODULATOR CONFIGURATION REGISTER

## 10.3.6.1 Description

**Table 22** Description of subaddress 9 (notes 1 and 2)

NAME	HIGH/LOW	FUNCTION
CH1MODE	HIGH	selects the hardware for the first sound carrier to operate in AM mode
	LOW	FM mode is assumed. This applies to both terrestrial and satellite FM reception.
FILTBW0, FILTBW1	–	selects the filter bandwidth for channel 1 and channel 2 in accordance with Table 25
CH2MOD0, CH2MOD1	–	These bits control the hardware for the second sound carrier in accordance with the truth Table 24.
IDAREA	HIGH	selects FM identification frequencies in accordance with the specification for Korea
	LOW	frequencies for Europe are selected (B/G and D/K standard)
IDMOD0, IDMOD1	–	These bits define the response time after which a sound mode identification result may be expected. The longer the time, the more reliable the identification.

**Notes**

1. It is recommended to switch the FM sound mode identification off whenever the received program is not a terrestrial 2-carrier sound.
2. Switching the identification off will reset the associated hardware to a defined state.

## 10.3.6.2 Definition

**Table 23** Subaddress 9 (note 1; see Table 22)

BIT	NAME	DESCRIPTION
7 (MSB)	IDMOD1	response time for FM sound mode identification
6	IDMOD0	
5	IDAREA	application area for FM identification
4	FILTBW1	selects filter bandwidth in accordance with Table 25
3	CH2MOD1	channel 2 receive mode
2	CH2MOD0	
1	FILTBW0	selects filter bandwidth in accordance with Table 25
0 (LSB)	CH1MODE	channel 1 receive mode

**Note**

1. The default setting at power-up is 00000000.

## Digital TV Sound Processor (DTVSP)

TDA9870A

**Table 24** Channel 2 receive mode (see Table 23)

B3	B2	CHANNEL 2
0	0	FM
0	1	AM
1	0	don't care

**Table 25** Filter bandwidth Channel 1 and Channel 2 (see Table 23)

B4	B1	FILTER BANDWIDTH		FILTER MODES
		CH1	CH2	
0	0	narrow	narrow	recommended for nominal terrestrial broadcast conditions and SAT with 2 carriers
0	1	extra wide	narrow	recommended only for high-deviation SAT mono carriers (e.g. obsolete main channel on Astra)
1	0	medium	medium	recommended for moderately overmodulated broadcast conditions
1	1	wide	wide	recommended for strongly overmodulated broadcast conditions

**Table 26** Identification mode (see Table 23)

B7	B6	IDENT MODE
0	0	slow
0	1	medium
1	0	fast
1	1	off/reset

## 10.3.7 FM DE-EMPHASIS REGISTER

## 10.3.7.1 Description

This register is used to select the proper de-emphasis characteristics as appropriate for the standard of the received carrier. Bits B3 to B0 apply to sound carrier 1, bits B7 to B4 apply to sound carrier 2. In the event of A2 reception, both groups must be set to the same characteristics.

## 10.3.7.2 Definition

**Table 27** Subaddress 10 (note 1)

BIT	NAME	DESCRIPTION
7 (MSB)	ADEEM2	adaptive de-emphasis on/off
6		time constant selection for FM de-emphasis
5		
4		
3	ADEEM1	adaptive de-emphasis on/off
2		time constant selection for FM de-emphasis
1		
0 (LSB)		

**Note**

1. The default setting at power-up is 00000000.

## Digital TV Sound Processor (DTVSP)

TDA9870A

**Table 28** De-emphasis

B6, B2	B5, B1	B4, B0	DE-EMPHASIS
0	0	0	50 $\mu$ s (Europe)
0	0	1	60 $\mu$ s
0	1	0	75 $\mu$ s (M standard)
0	1	1	J17
1	0	0	off

**Table 29** Description of bits ADEEM1 and ADEEM2 (note 1)

NAME	HIGH/LOW	FUNCTION
ADEEM1, ADEEM2	HIGH	Activates the adaptive de-emphasis function, which is required for certain satellite FM channels. The standard FM de-emphasis must then be set to 75 $\mu$ s.
	LOW	the adaptive de-emphasis is off

**Note**

- The FM de-emphasis gain is 0 dB at 40 Hz.

## 10.3.8 FM MATRIX REGISTER

## 10.3.8.1 Description

This register is used to select the proper dematrixing characteristics as appropriate for the standard of the received carrier and the related sound mode identification.

## 10.3.8.2 Definition

**Table 30** Subaddress 11 (notes 1)

MSB							LSB
B7	B6	B5	B4	B3	B2	B1	B0
0	0	0	0	0	see Table 31		

**Note**

- The default setting at power-up is 00000000.

## Digital TV Sound Processor (DTVSP)

TDA9870A

**Table 31** Description of Subaddress 11 (bits B2 to B0)

B2	B1	B0	L OUTPUT	R OUTPUT	MODE
0	0	0	CH1 input; note 1	CH1 input; note 1	mono 1
0	0	1	CH2 input; note 2	CH2 input; note 2	mono 2
0	1	0	CH1 input; note 1	CH2 input; note 2	dual
0	1	1	CH2 input; note 2	CH1 input; note 1	dual swapped
1	0	0	2CH1 input – CH2 input	CH2 input; note 2	stereo Europe
1	0	1	$\frac{\text{CH1 input} + \text{CH2 input}}{2}$	$\frac{\text{CH1 input} - \text{CH2 input}}{2}$	stereo Korea; note 3

**Notes**

1. CH1: audio signal from FM channel 1.
2. CH2: audio signal from FM channel 2.
3. See Table 6. For stereo Korea the dematrix applies 6 dB attenuation.

## 10.3.9 FM CHANNEL 1 LEVEL ADJUST REGISTER

## 10.3.9.1 Description

This register is used to correct for standard and station-dependent differences of signal levels. Table 32 applies to sound carrier 1.

## Digital TV Sound Processor (DTVSP)

## TDA9870A

## 10.3.9.2 Definition

Table 32 Subaddress 12

MSB							LSB	GAIN SETTING (dB)
B7	B6	B5	B4	B3	B2	B1	B0	
0	0	0	0	1	1	1	1	+15
0	0	0	0	1	1	1	0	+14
0	0	0	0	1	1	0	1	+13
0	0	0	0	1	1	0	0	+12
0	0	0	0	1	0	1	1	+11
0	0	0	0	1	0	1	0	+10
0	0	0	0	1	0	0	1	+9
0	0	0	0	1	0	0	0	+8
0	0	0	0	0	1	1	1	+7
0	0	0	0	0	1	1	0	+6
0	0	0	0	0	1	0	1	+5
0	0	0	0	0	1	0	0	+4
0	0	0	0	0	0	1	1	+3
0	0	0	0	0	0	1	0	+2
0	0	0	0	0	0	0	1	+1
0	0	0	0	0	0	0	0	0 (note 1)
0	0	0	1	1	1	1	1	-1
0	0	0	1	1	1	1	0	-2
0	0	0	1	1	1	0	1	-3
0	0	0	1	1	1	0	0	-4
0	0	0	1	1	0	1	1	-5
0	0	0	1	1	0	1	0	-6
0	0	0	1	1	0	0	1	-7
0	0	0	1	1	0	0	0	-8
0	0	0	1	0	1	1	1	-9
0	0	0	1	0	1	1	0	-10
0	0	0	1	0	1	0	1	-11
0	0	0	1	0	1	0	0	-12
0	0	0	1	0	0	1	1	-13
0	0	0	1	0	0	1	0	-14
0	0	0	1	0	0	0	1	-15
0	0	0	1	0	0	0	0	mute

**Note**

1. The default setting at power-up is 00000000.

## 10.3.10 FM CHANNEL 2 LEVEL ADJUST REGISTER

## 10.3.10.1 Description

This register is used to correct for standard and station-dependent differences of signal levels. Table 33 applies to sound carrier 2 in its FM and AM modes. In the event of A2, channels 1 and 2 should be adjusted to the same level.



## Digital TV Sound Processor (DTVSP)

## TDA9870A

## 10.3.10.2 Definition

Table 33 Subaddress 13

MSB							LSB	GAIN SETTING (dB)
B7	B6	B5	B4	B3	B2	B1	B0	
0	0	0	0	1	1	1	1	+15
0	0	0	0	1	1	1	0	+14
0	0	0	0	1	1	0	1	+13
0	0	0	0	1	1	0	0	+12
0	0	0	0	1	0	1	1	+11
0	0	0	0	1	0	1	0	+10
0	0	0	0	1	0	0	1	+9
0	0	0	0	1	0	0	0	+8
0	0	0	0	0	1	1	1	+7
0	0	0	0	0	1	1	0	+6
0	0	0	0	0	1	0	1	+5
0	0	0	0	0	1	0	0	+4
0	0	0	0	0	0	1	1	+3
0	0	0	0	0	0	1	0	+2
0	0	0	0	0	0	0	1	+1
0	0	0	0	0	0	0	0	0 (note 1)
0	0	0	1	1	1	1	1	-1
0	0	0	1	1	1	1	0	-2
0	0	0	1	1	1	0	1	-3
0	0	0	1	1	1	0	0	-4
0	0	0	1	1	0	1	1	-5
0	0	0	1	1	0	1	0	-6
0	0	0	1	1	0	0	1	-7
0	0	0	1	1	0	0	0	-8
0	0	0	1	0	1	1	1	-9
0	0	0	1	0	1	1	0	-10
0	0	0	1	0	1	0	1	-11
0	0	0	1	0	1	0	0	-12
0	0	0	1	0	0	1	1	-13
0	0	0	1	0	0	1	0	-14
0	0	0	1	0	0	0	1	-15
0	0	0	1	0	0	0	0	mute

## Note

1. The default setting at power-up is 00000000.

## Digital TV Sound Processor (DTVSP)

## TDA9870A

## 10.3.11 REGISTER 14

*10.3.11.1 Description*

Set to logic 0. This bits have not been assigned to a function.

## 10.3.12 REGISTER 15

*10.3.12.1 Description*

Set to logic 0. This bits have not been assigned to a function.

## 10.3.13 REGISTER 16

*10.3.13.1 Description*

Set to logic 0. This bits have not been assigned to a function.

## 10.3.14 REGISTER 17

*10.3.14.1 Description*

Set to logic 0. This bits have not been assigned to a function.

## 10.3.15 AUDIO MUTE CONTROL REGISTER

*10.3.15.1 Description*

When any of these bits are set HIGH, the corresponding pair of output channels will be muted. A LOW bit allows normal signal output.

There is a soft-mute facility for the Main and Auxiliary output channels to provide click-free muting independent of the volume control. This is switched on/off by bits MUTMAIN and MUTAUX.

*10.3.15.2 Definition***Table 34** Subaddress 18 (note 1)

BIT	NAME	DESCRIPTION
7 (MSB)	MUTI <sup>2</sup> S2	mute I <sup>2</sup> S2 outputs
6	MUTI <sup>2</sup> S1	mute I <sup>2</sup> S1 outputs
5	MUTDAC	mute internal DAC
4	MUTLINE	mute line outputs
3	MUTSC2	mute SCART 2 outputs
2	MUTSC1	mute SCART 1 outputs
1	MUTAUX	mute Auxiliary outputs
0 (LSB)	MUTMAIN	mute Main channels

**Note**

1. The default setting at power-up is 11111111.

## 10.3.16 DAC OUTPUT SELECT REGISTER

*10.3.16.1 Description*

This register is used to define both the signal source to be entered into the DAC and the mode of the digital matrix for signal selection. The DAC is used for signal output from digital sources at analog outputs.

The bits DACGAIN1 and DACGAIN2 can introduce some extra gain at the input to the DAC. DACGAIN1 adds 3 dB and DACGAIN2 adds 6 dB of gain, respectively.

Digital TV Sound Processor (DTVSP)

TDA9870A

10.3.16.2 Definition

**Table 35** Subaddress 19 (note 1)

MSB					LSB		
B7	B6	B5	B4	B3	B2	B1	B0
DACGAIN2 <sup>(2)</sup>	see Table 37			DACGAIN1 <sup>(2)</sup>	see Table 36		

**Notes**

1. The default setting at power-up is 00000000.
2. See Table 38.

**Table 36** Signal source left and right

B2	B1	B0	SIGNAL SOURCE	
			LEFT	RIGHT
0	0	0	FM left	FM right
0	0	1	don't care	
0	1	0	I <sup>2</sup> S1 left	I <sup>2</sup> S1 right
0	1	1	I <sup>2</sup> S2 left	I <sup>2</sup> S2 right
1	0	0	ADC left	ADC right
1	0	1	AVL left	AVL right
1	1	0	don't care	
1	1	1	don't care	

**Table 37** Bits B6 to B4

B6	B5	B4	L OUTPUT	R OUTPUT
0	0	0	L input	R input
0	0	1	L input	L input
0	1	0	R input	R input
0	1	1	R input	L input
1	0	0	$\frac{L+R}{2}$	$\frac{L+R}{2}$

**Table 38** Description of bits DACGAIN1 and DACGAIN2

B7	B3	GAIN (dB)
0	0	0
0	1	3
1	0	6
1	1	9

## Digital TV Sound Processor (DTVSP)

## TDA9870A

## 10.3.17 SCART 1 OUTPUT SELECT REGISTER

## 10.3.17.1 Description

This register is used to define both the signal source to be output at SCART 1 and the output channel selector mode.

## 10.3.17.2 Definition

**Table 39** Subaddress 20 (note 1)

MSB				LSB			
B7	B6	B5	B4	B3	B2	B1	B0
0	SC1GAIN <sup>(2)</sup>	see Table 41		0	see Table 40		

**Notes**

1. The default setting at power-up is 00000001.
2. See Table 42.

**Table 40** Signal source

B2	B1	B0	SIGNAL SOURCE
0	0	0	SCART 1 input
0	0	1	SCART 2 input
0	1	0	external input
0	1	1	mono input
1	0	0	DAC input

**Table 41** Bits B5 and B4

B5	B4	L OUTPUT	R OUTPUT
0	0	L input	R input
0	1	L input	L input
1	0	R input	R input
1	1	R input	L input

**Table 42** Description of bit SC1GAIN

NAME	HIGH/LOW	FUNCTION
SC1GAIN	HIGH	Activates the 3 dB gain stage at the SCART 1 output buffers. As any SCART input passes a 3 dB attenuator, this gain stage can be used to compensate that attenuation, resulting in a 0 dB insertion loss when copying from SCART 2 input to SCART 1 output. However, that gain must be used with great care, as it will cause signal clipping at high input levels.
	LOW	The audio signal will be output unchanged (0 dB gain).

## Digital TV Sound Processor (DTVSP)

## TDA9870A

## 10.3.18 SCART 2 OUTPUT SELECT REGISTER

## 10.3.18.1 Description

This register is used to define both the signal source to be output at SCART 2 and the output channel selector mode.

## 10.3.18.2 Definition

**Table 43** Subaddress 21 (note 1)

MSB					LSB		
B7	B6	B5	B4	B3	B2	B1	B0
0	SC2GAIN <sup>(2)</sup>	see Table 45		0	see Table 44		

**Notes**

1. The default setting at power-up is 00000000.
2. See Table 46.

**Table 44** Signal source

B2	B1	B0	SIGNAL SOURCE
0	0	0	SCART 1 input
0	0	1	SCART 2 input
0	1	0	external input
0	1	1	mono input
1	0	0	DAC input

**Table 45** Bits B5 and B4

B5	B4	L OUTPUT	R OUTPUT
0	0	L input	R input
0	1	L input	L input
1	0	R input	R input
1	1	R input	L input

**Table 46** Description of bit SC2GAIN

NAME	HIGH/LOW	FUNCTION
SC2GAIN	HIGH	Activates the 3 dB gain stage at the SCART 2 output buffers. As any SCART input passes a 3 dB attenuator, this gain stage can be used to compensate that attenuation, resulting in a 0 dB insertion loss when copying from SCART 1 input to SCART 2 output. However, that gain must be used with great care, as it will cause signal clipping at high input levels.
	LOW	The audio signal will be output unchanged (0 dB gain).

## Digital TV Sound Processor (DTVSP)

## TDA9870A

## 10.3.19 LINE OUTPUT SELECT REGISTER

## 10.3.19.1 Description

By definition, the line output conveys the same signal as the Main (loudspeaker) channel, but in a non-processed form. This register is used to characterize the signal to be output at the line output and define the output channel selector mode.

## 10.3.19.2 Definition

**Table 47** Subaddress 22 (note 1)

BIT	NAME	DESCRIPTION
7 (MSB)	–	set to logic 0
6	LINGAIN	line output gain on/off; see Table 49
5		see Table 48
4		
3	–	set to logic 0
2	–	set to logic 0
1	–	set to logic 0
0 (LSB)	LINSEL	select source for line output; see Table 49

**Note**

1. The default setting at power-up is 00000000.

**Table 48** Bits B5 and B4

B5	B4	L OUTPUT	R OUTPUT
0	0	L input	R input
0	1	L input	L input
1	0	R input	R input
1	1	R input	L input

**Table 49** Description of bits LINSEL and LINGAIN

NAME	HIGH/LOW	FUNCTION
LINSEL	HIGH	Specifies that a signal from an analog source is being processed in the Main channel. Analog signal sources comprise SCART 1 input, SCART 2 input, external input and mono input, i.e. any input to the ADC.
	LOW	Specifies that a signal from a digital source is being processed in the Main channel. Digital signal sources comprise FM, I <sup>2</sup> S1 input and I <sup>2</sup> S2 input.
LINGAIN	HIGH	Activates the 3 dB gain stage at the line output buffers.
	LOW	The audio signal will be output unchanged (0 dB gain).

## Digital TV Sound Processor (DTVSP)

## TDA9870A

## 10.3.20 ADC OUTPUT SELECT REGISTER

## 10.3.20.1 Description

This register is used to define the signal source for the ADC. There is no output channel selector, because all digital signal sinks of the ADC have their own matrix. Instead, a level adjustment facility for the ADC output is provided.

## 10.3.20.2 Definition

**Table 50** Subaddress 23 (note 1)

MSB				LSB			
B7	B6	B5	B4	B3	B2	B1	B0
see Table 51			see Table 52				

**Note**

1. The default setting at power-up is 00000000.

**Table 51** Signal source

B7	B6	B5	SIGNAL SOURCE
0	0	0	SCART 1 input
0	0	1	SCART 2 input
0	1	0	external input
0	1	1	mono input

## Digital TV Sound Processor (DTVSP)

## TDA9870A

**Table 52** ADC level adjust (note 1)

B4	B3	B2	B1	B0	GAIN SETTING (dB)
0	1	1	1	1	+15
0	1	1	1	0	+14
0	1	1	0	1	+13
0	1	1	0	0	+12
0	1	0	1	1	+11
0	1	0	1	0	+10
0	1	0	0	1	+9
0	1	0	0	0	+8
0	0	1	1	1	+7
0	0	1	1	0	+6
0	0	1	0	1	+5
0	0	1	0	0	+4
0	0	0	1	1	+3
0	0	0	1	0	+2
0	0	0	0	1	+1
0	0	0	0	0	0
1	1	1	1	1	-1
1	1	1	1	0	-2
1	1	1	0	1	-3
1	1	1	0	0	-4
1	1	0	1	1	-5
1	1	0	1	0	-6
1	1	0	0	1	-7
1	1	0	0	0	-8
1	0	1	1	1	-9
1	0	1	1	0	-10
1	0	1	0	1	-11
1	0	1	0	0	-12
1	0	0	1	1	-13
1	0	0	1	0	-14
1	0	0	0	1	-15
1	0	0	0	0	mute

**Note**

1. If the ADC level adjust is set to 0 dB a full-scale input signal to the ADC results into a level of -6 dB full-scale at the digital x-bar.



# Digital TV Sound Processor (DTVSP)

# TDA9870A

## 10.3.21 MAIN CHANNEL SELECT REGISTER

### 10.3.21.1 Description

This register is used to define both the signal source to be processed in the Main (loudspeaker) channel and the mode of the digital matrix for signal selection.

### 10.3.21.2 Definition

**Table 53** Subaddress 24 (note 1)

MSB							LSB
B7	B6	B5	B4	B3	B2	B1	B0
0	see Table 55			0	see Table 54		

**Note**

1. The default setting at power-up is 00000000.

**Table 54** Signal source

B2	B1	B0	SIGNAL SOURCE
0	0	0	FM input
0	0	1	don't care
0	1	0	I <sup>2</sup> S1 input
0	1	1	I <sup>2</sup> S2 input
1	0	0	ADC input

**Table 55** Bits B6 to B4

B6	B5	B4	L OUTPUT	R OUTPUT
0	0	0	L input	R input
0	0	1	L input	L input
0	1	0	R input	R input
0	1	1	R input	L input
1	0	0	$\frac{L+R}{2}$	$\frac{L+R}{2}$

## Digital TV Sound Processor (DTVSP)

## TDA9870A

## 10.3.22 AUDIO EFFECTS REGISTER

## 10.3.22.1 Definition

**Table 56** Subaddress 25 (note 1; see Table 60)

MSB				LSB			
B7	B6	B5	B4	B3	B2	B1	B0
0	0	SPATIAL1 <sup>(2)</sup>	SPATIAL0 <sup>(2)</sup>	PSEUDO1 <sup>(3)</sup>	PSEUDO0 <sup>(3)</sup>	AVL1 <sup>(4)</sup>	AVL0 <sup>(4)</sup>

**Notes**

1. The default setting at power-up is 00000000.
2. See Table 59.
3. See Table 58.
4. See Table 57.

**Table 57** AVL control mode

B1	B0	AVL MODE
0	0	off/reset
0	1	short decay
1	0	medium decay
1	1	long decay

**Table 58** Pseudo control setting

B3	B2	PSEUDO SETTING (Hz)
0	0	off
0	1	300
1	0	200
1	1	150

**Table 59** Spatial control setting

B5	B4	SPATIAL SETTING (%)
0	0	off
0	1	30
1	0	40
1	1	52

# Digital TV Sound Processor (DTVSP)

# TDA9870A

**Table 60** Description of Table 56 (notes 1, 2 and 3)

NAME	FUNCTION
AVL0, AVL1	these bits set the mode of operation of the automatic volume level control function at the entrance to the Main (loudspeaker) channel
PSEUDO0, PSEUDO1	These bits set the amount of the effect function (pseudo stereo) for mono signals in the Main channel. This function should be activated only in accordance with the result of the sound mode identification.
SPATIAL0, SPATIAL1	These bits set the amount of the effect function (stereo base width expansion) for stereo signals in the Main channel. This function should be activated only in accordance with the result of the sound mode identification.

**Notes**

1. Switching the AVL off will reset the associated hardware to a defined state.
2. When the signal source for the Main channel is changed while the AVL is on, the AVL needs to be reset in order to avoid excessive settling times. This can be achieved by switching the AVL off and on again.
3. The pseudo stereo function is based on an all-pass filter. A 90 degrees phase shift occurs at the frequencies stated in Table 58. There is a gain of 3 dB in the left audio channel.

10.3.23 VOLUME CONTROL REGISTERS (MAIN)

10.3.23.1 Description

These two registers control the volume setting of the Main (loudspeaker) channel. The register at subaddress 26 applies to the left channel signal, while the register at subaddress 27 applies to the right channel signal.

Balance control is exercised by offsetting the left and right channel volume settings.

10.3.23.2 Definition

**Table 61** Subaddresses 26 and 27

MSB							LSB	VOLUME SETTING (dB)
B7	B6	B5	B4	B3	B2	B1	B0	
0	0	0	1	1	0	0	0	+24
0	0	0	1	0	1	1	1	+23
0	0	0	1	0	1	1	0	+22
0	0	0	1	0	1	0	1	+21
0	0	0	1	0	1	0	0	+20
0	0	0	1	0	0	1	1	+19
0	0	0	1	0	0	1	0	+18
0	0	0	1	0	0	0	1	+17
0	0	0	1	0	0	0	0	+16
0	0	0	0	1	1	1	1	+15
0	0	0	0	1	1	1	0	+14
0	0	0	0	1	1	0	1	+13
0	0	0	0	1	1	0	0	+12
0	0	0	0	1	0	1	1	+11
0	0	0	0	1	0	1	0	+10
0	0	0	0	1	0	0	1	+9

## Digital TV Sound Processor (DTVSP)

## TDA9870A

MSB							LSB	VOLUME SETTING (dB)
B7	B6	B5	B4	B3	B2	B1	B0	
0	0	0	0	1	0	0	0	+8
0	0	0	0	0	1	1	1	+7
0	0	0	0	0	1	1	0	+6
0	0	0	0	0	1	0	1	+5
0	0	0	0	0	1	0	0	+4
0	0	0	0	0	0	1	1	+3
0	0	0	0	0	0	1	0	+2
0	0	0	0	0	0	0	1	+1
0	0	0	0	0	0	0	0	0
1	1	1	1	1	1	1	1	-1
1	1	1	1	1	1	1	0	-2
1	1	1	1	1	1	0	1	-3
1	1	1	1	1	1	0	0	-4
1	1	1	1	1	0	1	1	-5
1	1	1	1	1	0	1	0	-6
1	1	1	1	1	0	0	1	-7
1	1	1	1	1	0	0	0	-8
1	1	1	1	0	1	1	1	-9
1	1	1	1	0	1	1	0	-10
1	1	1	1	0	1	0	1	-11
1	1	1	1	0	1	0	0	-12
1	1	1	1	0	0	1	1	-13
1	1	1	1	0	0	1	0	-14
1	1	1	1	0	0	0	1	-15
1	1	1	1	0	0	0	0	-16
1	1	1	1	0	1	1	1	-17
1	1	1	1	0	1	1	0	-18
1	1	1	1	0	1	0	1	-19
1	1	1	1	0	1	1	0	-20
1	1	1	1	0	1	0	1	-21
1	1	1	1	0	1	0	0	-22
1	1	1	1	0	1	0	1	-23
1	1	1	1	0	1	0	0	-24
1	1	1	1	0	0	1	1	-25
1	1	1	1	0	0	1	0	-26
1	1	1	1	0	0	1	0	-27
1	1	1	1	0	0	1	0	-28
1	1	1	1	0	0	0	1	-29
1	1	1	1	0	0	0	0	-30

## Digital TV Sound Processor (DTVSP)

## TDA9870A

MSB							LSB	VOLUME SETTING (dB)
B7	B6	B5	B4	B3	B2	B1	B0	
1	1	1	0	0	0	0	1	-31
1	1	1	0	0	0	0	0	-32
1	1	0	1	1	1	1	1	-33
1	1	0	1	1	1	1	0	-34
1	1	0	1	1	1	0	1	-35
1	1	0	1	1	1	0	0	-36
1	1	0	1	1	0	1	1	-37
1	1	0	1	1	0	1	0	-38
1	1	0	1	1	0	0	1	-39
1	1	0	1	1	0	0	0	-40
1	1	0	1	0	1	1	1	-41
1	1	0	1	0	1	1	0	-42
1	1	0	1	0	1	0	1	-43
1	1	0	1	0	1	0	0	-44
1	1	0	1	0	0	1	1	-45
1	1	0	1	0	0	1	0	-46
1	1	0	1	0	0	0	1	-47
1	1	0	1	0	0	0	0	-48
1	1	0	0	1	1	1	1	-49
1	1	0	0	1	1	1	0	-50
1	1	0	0	1	1	0	1	-51
1	1	0	0	1	1	0	0	-52
1	1	0	0	1	0	1	1	-53
1	1	0	0	1	0	1	0	-54
1	1	0	0	1	0	0	1	-55
1	1	0	0	1	0	0	0	-56
1	1	0	0	0	1	1	1	-57
1	1	0	0	0	1	1	0	-58
1	1	0	0	0	1	0	1	-59
1	1	0	0	0	1	0	0	-60
1	1	0	0	0	0	1	1	-61
1	1	0	0	0	0	1	0	-62
1	1	0	0	0	0	0	1	-63
1	1	0	0	0	0	0	0	-64
1	0	1	1	1	1	1	1	-65
1	0	1	1	1	1	1	0	-66
1	0	1	1	1	1	0	1	-67
1	0	1	1	1	1	0	0	-68
1	0	1	1	1	0	1	1	-69

## Digital TV Sound Processor (DTVSP)

TDA9870A

MSB							LSB		VOLUME SETTING (dB)
B7	B6	B5	B4	B3	B2	B1	B0		
1	0	1	1	1	0	1	0	-70	
1	0	1	1	1	0	0	1	-71	
1	0	1	1	1	0	0	0	-72	
1	0	1	1	0	1	1	1	-73	
1	0	1	1	0	1	1	0	-74	
1	0	1	1	0	1	0	1	-75	
1	0	1	1	0	1	0	0	-76	
1	0	1	1	0	0	1	1	-77	
1	0	1	1	0	0	1	0	-78	
1	0	1	1	0	0	0	1	-79	
1	0	1	1	0	0	0	0	-80	
1	0	1	0	1	1	1	1	-81	
1	0	1	0	1	1	1	0	-82	
1	0	1	0	1	1	0	1	-83	
1	0	1	0	1	1	0	0	mute (note 1)	

**Note**

1. The default setting at power-up is 10101100.

## Digital TV Sound Processor (DTVSP)

## TDA9870A

## 10.3.24 CONTOUR CONTROL REGISTER

## 10.3.24.1 Description

This register is used to apply the contour or loudness function (physiological volume control) to the left and right signal channels of the Main channel by means of an extra bass boost. The gain setting must be chosen in accordance with the volume control setting for the Main channel. For example, the contour gain could be incremented for every 5 dB, or so, of decrease of the volume setting. This needs to be done by the microcontroller. The 0 dB contour setting is equal to contour off.

## 10.3.24.2 Definition

Table 62 Subaddress 28

MSB							LSB	CONTOUR GAIN (dB)
B7	B6	B5	B4	B3	B2	B1	B0	
0	0	0	1	0	0	1	0	18
0	0	0	1	0	0	0	1	17
0	0	0	1	0	0	0	0	16
0	0	0	0	1	1	1	1	15
0	0	0	0	1	1	1	0	14
0	0	0	0	1	1	0	1	13
0	0	0	0	1	1	0	0	12
0	0	0	0	1	0	1	1	11
0	0	0	0	1	0	1	0	10
0	0	0	0	1	0	0	1	9
0	0	0	0	1	0	0	0	8
0	0	0	0	0	1	1	1	7
0	0	0	0	0	1	1	0	6
0	0	0	0	0	1	0	1	5
0	0	0	0	0	1	0	0	4
0	0	0	0	0	0	1	1	3
0	0	0	0	0	0	1	0	2
0	0	0	0	0	0	0	1	1
0	0	0	0	0	0	0	0	0 (note 1)

## Note

1. The default setting at power-up is 00000000.

## Digital TV Sound Processor (DTVSP)

## TDA9870A

## 10.3.25 BASS CONTROL REGISTER (MAIN)

## 10.3.25.1 Description

This register is used to apply bass control to the left and right signal channels of the Main channel.

## 10.3.25.2 Definition

Table 63 Subaddress 29

MSB							LSB		BASS SETTING (dB)
B7	B6	B5	B4	B3	B2	B1	B0		
0	0	0	0	1	1	1	1	+15	
0	0	0	0	1	1	1	0	+14	
0	0	0	0	1	1	0	1	+13	
0	0	0	0	1	1	0	0	+12	
0	0	0	0	1	0	1	1	+11	
0	0	0	0	1	0	1	0	+10	
0	0	0	0	1	0	0	1	+9	
0	0	0	0	1	0	0	0	+8	
0	0	0	0	0	1	1	1	+7	
0	0	0	0	0	1	1	0	+6	
0	0	0	0	0	1	0	1	+5	
0	0	0	0	0	1	0	0	+4	
0	0	0	0	0	0	1	1	+3	
0	0	0	0	0	0	1	0	+2	
0	0	0	0	0	0	0	1	+1	
0	0	0	0	0	0	0	0	0 (note 1)	
0	0	0	1	1	1	1	1	-1	
0	0	0	1	1	1	1	0	-2	
0	0	0	1	1	1	0	1	-3	
0	0	0	1	1	1	0	0	-4	
0	0	0	1	1	0	1	1	-5	
0	0	0	1	1	0	1	0	-6	
0	0	0	1	1	0	0	1	-7	
0	0	0	1	1	0	0	0	-8	
0	0	0	1	0	1	1	1	-9	
0	0	0	1	0	1	1	0	-10	
0	0	0	1	0	1	0	1	-11	
0	0	0	1	0	1	0	0	-12	

## Note

1. The default setting at power-up is 00000000.



## Digital TV Sound Processor (DTVSP)

## TDA9870A

## 10.3.26 TREBLE CONTROL REGISTER (MAIN)

## 10.3.26.1 Description

This register is used to apply treble control to the left and right signal channels of the Main channel.

## 10.3.26.2 Definition

Table 64 Subaddress 30

MSB							LSB		TREBLE SETTING (dB)
B7	B6	B5	B4	B3	B2	B1	B0		
0	0	0	0	1	1	0	0	+12	
0	0	0	0	1	0	1	1	+11	
0	0	0	0	1	0	1	0	+10	
0	0	0	0	1	0	0	1	+9	
0	0	0	0	1	0	0	0	+8	
0	0	0	0	0	1	1	1	+7	
0	0	0	0	0	1	1	0	+6	
0	0	0	0	0	1	0	1	+5	
0	0	0	0	0	1	0	0	+4	
0	0	0	0	0	0	1	1	+3	
0	0	0	0	0	0	1	0	+2	
0	0	0	0	0	0	0	1	+1	
0	0	0	0	0	0	0	0	0 (note 1)	
0	0	0	1	1	1	1	1	-1	
0	0	0	1	1	1	1	0	-2	
0	0	0	1	1	1	0	1	-3	
0	0	0	1	1	1	0	0	-4	
0	0	0	1	1	0	1	1	-5	
0	0	0	1	1	0	1	0	-6	
0	0	0	1	1	0	0	1	-7	
0	0	0	1	1	0	0	0	-8	
0	0	0	1	0	1	1	1	-9	
0	0	0	1	0	1	1	0	-10	
0	0	0	1	0	1	0	1	-11	
0	0	0	1	0	1	0	0	-12	

**Note**

1. The default setting at power-up is 00000000.

Digital TV Sound Processor (DTVSP)

TDA9870A

10.3.27 AUXILIARY CHANNEL SELECT REGISTER

10.3.27.1 Description

This register is used to define both the signal source to be processed in the Auxiliary (headphone) channel and the mode of the digital matrix for signal selection.

10.3.27.2 Definition

**Table 65** Subaddress 31 (note 1)

MSB				LSB			
B7	B6	B5	B4	B3	B2	B1	B0
0	see Table 67			0	see Table 66		

**Note**

1. The default setting at power-up is 00000000.

**Table 66** Signal source

B2	B1	B0	SIGNAL SOURCE
0	0	0	FM input
0	0	1	don't care
0	1	0	I <sup>2</sup> S1 input
0	1	1	I <sup>2</sup> S2 input
1	0	0	ADC input
1	0	1	AVL input

**Table 67** Bits B6 to B4

B6	B5	B4	L OUTPUT	R OUTPUT
0	0	0	L input	R input
0	0	1	L input	L input
0	1	0	R input	R input
0	1	1	R input	L input
1	0	0	$\frac{L + R}{2}$	$\frac{L + R}{2}$

## Digital TV Sound Processor (DTVSP)

## TDA9870A

## 10.3.28 VOLUME CONTROL REGISTERS (AUXILIARY)

## 10.3.28.1 Description

These two registers control the volume setting of the Auxiliary (headphone) channel. The register at subaddress 32 applies to the left channel signal, while the register at subaddress 33 applies to the right channel signal.

Balance control is exercised by offsetting the left and right channel volume settings.

## 10.3.28.2 Definition

Table 68 Subaddresses 32 and 33

MSB				LSB				VOLUME SETTING (dB)
B7	B6	B5	B4	B3	B2	B1	B0	
0	0	0	1	1	0	0	0	+24
0	0	0	1	0	1	1	1	+23
0	0	0	1	0	1	1	0	+22
0	0	0	1	0	1	0	1	+21
0	0	0	1	0	1	0	0	+20
0	0	0	1	0	0	1	1	+19
0	0	0	1	0	0	1	0	+18
0	0	0	1	0	0	0	1	+17
0	0	0	1	0	0	0	0	+16
0	0	0	0	1	1	1	1	+15
0	0	0	0	1	1	1	0	+14
0	0	0	0	1	1	0	1	+13
0	0	0	0	1	1	0	0	+12
0	0	0	0	1	0	1	1	+11
0	0	0	0	1	0	1	0	+10
0	0	0	0	1	0	0	1	+9
0	0	0	0	1	0	0	0	+8
0	0	0	0	0	1	1	1	+7
0	0	0	0	0	1	1	0	+6
0	0	0	0	0	1	0	1	+5
0	0	0	0	0	1	0	0	+4
0	0	0	0	0	0	1	1	+3
0	0	0	0	0	0	1	0	+2
0	0	0	0	0	0	0	1	+1
0	0	0	0	0	0	0	0	0
1	1	1	1	1	1	1	1	-1
1	1	1	1	1	1	1	0	-2
1	1	1	1	1	1	0	1	-3
1	1	1	1	1	1	0	0	-4
1	1	1	1	1	0	1	1	-5
1	1	1	1	1	0	1	0	-6
1	1	1	1	1	0	0	1	-7

## Digital TV Sound Processor (DTVSP)

## TDA9870A

MSB							LSB	VOLUME SETTING (dB)
B7	B6	B5	B4	B3	B2	B1	B0	
1	1	1	1	1	0	0	0	-8
1	1	1	1	0	1	1	1	-9
1	1	1	1	0	1	1	0	-10
1	1	1	1	0	1	0	1	-11
1	1	1	1	0	1	0	0	-12
1	1	1	1	0	0	1	1	-13
1	1	1	1	0	0	1	0	-14
1	1	1	1	0	0	0	1	-15
1	1	1	1	0	0	0	0	-16
1	1	1	0	1	1	1	1	-17
1	1	1	0	1	1	1	0	-18
1	1	1	0	1	1	0	1	-19
1	1	1	0	1	1	0	0	-20
1	1	1	0	1	0	1	1	-21
1	1	1	0	1	0	1	0	-22
1	1	1	0	1	0	0	1	-23
1	1	1	0	1	0	0	0	-24
1	1	1	0	0	1	1	1	-25
1	1	1	0	0	1	1	0	-26
1	1	1	0	0	1	0	1	-27
1	1	1	0	0	1	0	0	-28
1	1	1	0	0	0	1	1	-29
1	1	1	0	0	0	1	0	-30
1	1	1	0	0	0	0	1	-31
1	1	1	0	0	0	0	0	-32
1	1	0	1	1	1	1	1	-33
1	1	0	1	1	1	1	0	-34
1	1	0	1	1	1	0	1	-35
1	1	0	1	1	1	0	0	-36
1	1	0	1	1	0	1	1	-37
1	1	0	1	1	0	1	0	-38
1	1	0	1	1	0	0	1	-39
1	1	0	1	1	0	0	0	-40
1	1	0	1	0	1	1	1	-41
1	1	0	1	0	1	1	0	-42
1	1	0	1	0	1	0	1	-43
1	1	0	1	0	1	0	0	-44
1	1	0	1	0	0	1	1	-45
1	1	0	1	0	0	1	0	-46
1	1	0	1	0	0	0	1	-47
1	1	0	1	0	0	0	0	-48

## Digital TV Sound Processor (DTVSP)

## TDA9870A

MSB				LSB				VOLUME SETTING (dB)
B7	B6	B5	B4	B3	B2	B1	B0	
1	1	0	0	1	1	1	1	-49
1	1	0	0	1	1	1	0	-50
1	1	0	0	1	1	0	1	-51
1	1	0	0	1	1	0	0	-52
1	1	0	0	1	0	1	1	-53
1	1	0	0	1	0	1	0	-54
1	1	0	0	1	0	0	1	-55
1	1	0	0	1	0	0	0	-56
1	1	0	0	0	1	1	1	-57
1	1	0	0	0	1	1	0	-58
1	1	0	0	0	1	0	1	-59
1	1	0	0	0	1	0	0	-60
1	1	0	0	0	0	1	1	-61
1	1	0	0	0	0	1	0	-62
1	1	0	0	0	0	0	1	-63
1	1	0	0	0	0	0	0	-64
1	0	1	1	1	1	1	1	-65
1	0	1	1	1	1	1	0	-66
1	0	1	1	1	1	0	1	-67
1	0	1	1	1	1	0	0	-68
1	0	1	1	1	0	1	1	-69
1	0	1	1	1	0	1	0	-70
1	0	1	1	1	0	0	1	-71
1	0	1	1	1	0	0	0	-72
1	0	1	1	0	1	1	1	-73
1	0	1	1	0	1	1	0	-74
1	0	1	1	0	1	0	1	-75
1	0	1	1	0	1	0	0	-76
1	0	1	1	0	0	1	1	-77
1	0	1	1	0	0	1	0	-78
1	0	1	1	0	0	0	1	-79
1	0	1	1	0	0	0	0	-80
1	0	1	0	1	1	1	1	-81
1	0	1	0	1	1	1	0	-82
1	0	1	0	1	1	0	1	-83
1	0	1	0	1	1	0	0	mute (note 1)

**Note**

1. The default setting at power-up is 10101100.

## Digital TV Sound Processor (DTVSP)

## TDA9870A

## 10.3.29 BASS CONTROL REGISTER (AUXILIARY)

## 10.3.29.1 Description

This register is used to apply bass control to the left and right signal channels of the Auxiliary channel.

## 10.3.29.2 Definition

Table 69 Subaddress 34

MSB							LSB		BASS SETTING (dB)
B7	B6	B5	B4	B3	B2	B1	B0		
0	0	0	0	1	1	1	1	+15	
0	0	0	0	1	1	1	0	+14	
0	0	0	0	1	1	0	1	+13	
0	0	0	0	1	1	0	0	+12	
0	0	0	0	1	0	1	1	+11	
0	0	0	0	1	0	1	0	+10	
0	0	0	0	1	0	0	1	+9	
0	0	0	0	1	0	0	0	+8	
0	0	0	0	0	1	1	1	+7	
0	0	0	0	0	1	1	0	+6	
0	0	0	0	0	1	0	1	+5	
0	0	0	0	0	1	0	0	+4	
0	0	0	0	0	0	1	1	+3	
0	0	0	0	0	0	1	0	+2	
0	0	0	0	0	0	0	1	+1	
0	0	0	0	0	0	0	0	0 (note 1)	
0	0	0	1	1	1	1	1	-1	
0	0	0	1	1	1	1	0	-2	
0	0	0	1	1	1	0	1	-3	
0	0	0	1	1	1	0	0	-4	
0	0	0	1	1	0	1	1	-5	
0	0	0	1	1	0	1	0	-6	
0	0	0	1	1	0	0	1	-7	
0	0	0	1	1	0	0	0	-8	
0	0	0	1	0	1	1	1	-9	
0	0	0	1	0	1	1	0	-10	
0	0	0	1	0	1	0	1	-11	
0	0	0	1	0	1	0	0	-12	

## Note

1. The default setting at power-up is 00000000.

## Digital TV Sound Processor (DTVSP)

## TDA9870A

## 10.3.30 TREBLE CONTROL REGISTER (AUXILIARY)

## 10.3.30.1 Description

This register is used to apply treble control to the left and right signal channels of the Auxiliary channel.

## 10.3.30.2 Definition

Table 70 Subaddress 35

MSB							LSB		TREBLE SETTING (dB)
B7	B6	B5	B4	B3	B2	B1	B0		
X	X	X	0	1	1	0	0	+12	
X	X	X	0	1	0	1	1	+11	
X	X	X	0	1	0	1	0	+10	
X	X	X	0	1	0	0	1	+9	
X	X	X	0	1	0	0	0	+8	
X	X	X	0	0	1	1	1	+7	
X	X	X	0	0	1	1	0	+6	
X	X	X	0	0	1	0	1	+5	
X	X	X	0	0	1	0	0	+4	
X	X	X	0	0	0	1	1	+3	
X	X	X	0	0	0	1	0	+2	
X	X	X	0	0	0	0	1	+1	
X	X	X	0	0	0	0	0	0 (note 1)	
X	X	X	1	1	1	1	1	-1	
X	X	X	1	1	1	1	0	-2	
X	X	X	1	1	1	0	1	-3	
X	X	X	1	1	1	0	0	-4	
X	X	X	1	1	0	1	1	-5	
X	X	X	1	1	0	1	0	-6	
X	X	X	1	1	0	0	1	-7	
X	X	X	1	1	0	0	0	-8	
X	X	X	1	0	1	1	1	-9	
X	X	X	1	0	1	1	0	-10	
X	X	X	1	0	1	0	1	-11	
X	X	X	1	0	1	0	0	-12	

**Note**

1. The default setting at power-up is 00000000.

## Digital TV Sound Processor (DTVSP)

## TDA9870A

## 10.3.31 FEATURE INTERFACE CONFIGURATION REGISTER

## 10.3.31.1 Definition

**Table 71** Subaddress 36 (note 1)

MSB							LSB
B7	B6	B5	B4	B3	B2	B1	B0
0	0	0	SYSCL1 <sup>(2)</sup>	SYSCL0 <sup>(2)</sup>	SYSOUT <sup>(3)</sup>	I <sup>2</sup> SFORM <sup>(4)</sup>	I <sup>2</sup> SOUT <sup>(5)</sup>

**Notes**

1. The default setting at power-up is 00000000.
2. System clock frequency select; see Table 72.
3. System clock output on/off; see Table 73.
4. Serial output format; see Table 73.
5. I<sup>2</sup>S-bus outputs on/off; see Table 73.

**Table 72** System clock frequency select

B4	B3	SYSCLK OUTPUT	FREQUENCY (MHz)
0	0	256f <sub>s</sub>	8.192
0	1	384f <sub>s</sub>	12.288
1	0	512f <sub>s</sub>	16.384; note 1
1	1	768f <sub>s</sub>	24.576

**Note**

1. With 16.384 MHz, the duty cycle is 33% : 67%.

**Table 73** Description of Table 71

NAME	HIGH/LOW	FUNCTION
I <sup>2</sup> SOUT	HIGH	Enables the output of serial audio data (2 pins) plus serial bit clock and word select in a format determined by the I <sup>2</sup> SFORM bit. The TDA9870A is then an I <sup>2</sup> S-bus master.
	LOW	the outputs mentioned will be 3-stated, thereby improving the EMC performance
I <sup>2</sup> SFORM	HIGH	an MSB-aligned, MSB-first output format is selected, i.e. a level change at the word select pin indicates the beginning of a new audio sample
	LOW	the standard I <sup>2</sup> S-bus output format is selected
SYSOUT	HIGH	enables the output of a system (or master) clock signal at pin SYSCLK
	LOW	the output will be off, thereby improving the EMC performance



# Digital TV Sound Processor (DTVSP)

# TDA9870A

## 10.3.32 I<sup>2</sup>S1 OUTPUT SELECT REGISTER

### 10.3.32.1 Description

This register is used to define both the signal source to be output at I<sup>2</sup>S1 and the mode of the digital matrix for signal selection.

### 10.3.32.2 Definition

**Table 74** Subaddress 37 (note 1)

MSB				LSB			
B7	B6	B5	B4	B3	B2	B1	B0
0	see Table 76			0	see Table 75		

**Note**

1. The default setting at power-up is 00000000.

**Table 75** Signal source (note 1)

B2	B1	B0	SIGNAL SOURCE
0	0	0	FM output
0	0	1	don't care
0	1	0	I <sup>2</sup> S1 input
0	1	1	I <sup>2</sup> S2 input
1	0	0	ADC output
1	0	1	AVL output
1	1	0	Auxiliary output
1	1	1	Main output

**Note**

1. The Main and Auxiliary channel outputs will not contain the beeper signal.

**Table 76** Bits B6 to B4

B6	B5	B4	L OUTPUT	R OUTPUT
0	0	0	L input	R input
0	0	1	L input	L input
0	1	0	R input	R input
0	1	1	R input	L input
1	0	0	$\frac{L + R}{2}$	$\frac{L + R}{2}$

Digital TV Sound Processor (DTVSP)

TDA9870A

10.3.33 I<sup>2</sup>S1 INPUT LEVEL ADJUST REGISTER

10.3.33.1 Description

This register is used to adjust the input level at the I<sup>2</sup>S1 interface. Left and right signal channel are treated identically.

10.3.33.2 Definition

Table 77 Subaddress 38

MSB							LSB		GAIN SETTING (dB)
B7	B6	B5	B4	B3	B2	B1	B0		
0	0	0	0	1	1	1	1	+15	
0	0	0	0	1	1	1	0	+14	
0	0	0	0	1	1	0	1	+13	
0	0	0	0	1	1	0	0	+12	
0	0	0	0	1	0	1	1	+11	
0	0	0	0	1	0	1	0	+10	
0	0	0	0	1	0	0	1	+9	
0	0	0	0	1	0	0	0	+8	
0	0	0	0	0	1	1	1	+7	
0	0	0	0	0	1	1	0	+6	
0	0	0	0	0	1	0	1	+5	
0	0	0	0	0	1	0	0	+4	
0	0	0	0	0	0	1	1	+3	
0	0	0	0	0	0	1	0	+2	
0	0	0	0	0	0	0	1	+1	
0	0	0	0	0	0	0	0	0 (note 1)	
0	0	0	1	1	1	1	1	-1	
0	0	0	1	1	1	1	0	-2	
0	0	0	1	1	1	0	1	-3	
0	0	0	1	1	1	0	0	-4	
0	0	0	1	1	0	1	1	-5	
0	0	0	1	1	0	1	0	-6	
0	0	0	1	1	0	0	1	-7	
0	0	0	1	1	0	0	0	-8	
0	0	0	1	0	1	1	1	-9	
0	0	0	1	0	1	1	0	-10	
0	0	0	1	0	1	0	1	-11	
0	0	0	1	0	1	0	0	-12	
0	0	0	1	0	0	1	1	-13	
0	0	0	1	0	0	1	0	-14	
0	0	0	1	0	0	0	1	-15	
0	0	0	1	0	0	0	0	mute	

Note

1. The default setting at power-up is 00000000.

## Digital TV Sound Processor (DTVSP)

## TDA9870A

10.3.34 I<sup>2</sup>S1 OUTPUT LEVEL ADJUST REGISTER

## 10.3.34.1 Description

This register is used to adjust the output level at the I<sup>2</sup>S1 interface. Left and right signal channel are treated identically.

## 10.3.34.2 Definition

Table 78 Subaddress 39

MSB							LSB		GAIN SETTING (dB)
B7	B6	B5	B4	B3	B2	B1	B0		
0	0	0	0	1	1	1	1	+15	
0	0	0	0	1	1	1	0	+14	
0	0	0	0	1	1	0	1	+13	
0	0	0	0	1	1	0	0	+12	
0	0	0	0	1	0	1	1	+11	
0	0	0	0	1	0	1	0	+10	
0	0	0	0	1	0	0	1	+9	
0	0	0	0	1	0	0	0	+8	
0	0	0	0	0	1	1	1	+7	
0	0	0	0	0	1	1	0	+6	
0	0	0	0	0	1	0	1	+5	
0	0	0	0	0	1	0	0	+4	
0	0	0	0	0	0	1	1	+3	
0	0	0	0	0	0	1	0	+2	
0	0	0	0	0	0	0	1	+1	
0	0	0	0	0	0	0	0	0 (note 1)	
0	0	0	1	1	1	1	1	-1	
0	0	0	1	1	1	1	0	-2	
0	0	0	1	1	1	0	1	-3	
0	0	0	1	1	1	0	0	-4	
0	0	0	1	1	0	1	1	-5	
0	0	0	1	1	0	1	0	-6	
0	0	0	1	1	0	0	1	-7	
0	0	0	1	1	0	0	0	-8	
0	0	0	1	0	1	1	1	-9	
0	0	0	1	0	1	1	0	-10	
0	0	0	1	0	1	0	1	-11	
0	0	0	1	0	1	0	0	-12	
0	0	0	1	0	0	1	1	-13	
0	0	0	1	0	0	1	0	-14	
0	0	0	1	0	0	0	1	-15	
0	0	0	1	0	0	0	0	mute	

## Note

1. The default setting at power-up is 00000000.

## Digital TV Sound Processor (DTVSP)

## TDA9870A

10.3.35 I<sup>2</sup>S2 OUTPUT SELECT REGISTER

## 10.3.35.1 Description

This register is used to define both the signal source to be output at I<sup>2</sup>S2 and the mode of the digital matrix for signal selection.

## 10.3.35.2 Definition

**Table 79** Subaddress 40 (note 1)

MSB				LSB			
B7	B6	B5	B4	B3	B2	B1	B0
0	see Table 81			0	see Table 80		

**Note**

- The default setting at power-up is 00000000.

**Table 80** Signal source (note 1)

B2	B1	B0	SIGNAL SOURCE
0	0	0	FM output
0	0	1	don't care
0	1	0	I <sup>2</sup> S1 input
0	1	1	I <sup>2</sup> S2 input
1	0	0	ADC output
1	0	1	AVL output
1	1	0	Auxiliary output
1	1	1	Main output

**Note**

- The Main and Auxiliary channel outputs will not contain the beeper signal.

**Table 81** Bits B6 to B4

B6	B5	B4	L OUTPUT	R OUTPUT
0	0	0	L input	R input
0	0	1	L input	L input
0	1	0	R input	R input
0	1	1	R input	L input
1	0	0	$\frac{L+R}{2}$	$\frac{L+R}{2}$

## Digital TV Sound Processor (DTVSP)

## TDA9870A

10.3.36 I<sup>2</sup>S2 INPUT LEVEL ADJUST REGISTER

## 10.3.36.1 Description

This register is used to adjust the input level at the I<sup>2</sup>S2 interface. Left and right signal channel are treated identically.

## 10.3.36.2 Definition

Table 82 Subaddress 41

MSB							LSB		GAIN SETTING (dB)
B7	B6	B5	B4	B3	B2	B1	B0		
0	0	0	0	1	1	1	1	+15	
0	0	0	0	1	1	1	0	+14	
0	0	0	0	1	1	0	1	+13	
0	0	0	0	1	1	0	0	+12	
0	0	0	0	1	0	1	1	+11	
0	0	0	0	1	0	1	0	+10	
0	0	0	0	1	0	0	1	+9	
0	0	0	0	1	0	0	0	+8	
0	0	0	0	0	1	1	1	+7	
0	0	0	0	0	1	1	0	+6	
0	0	0	0	0	1	0	1	+5	
0	0	0	0	0	1	0	0	+4	
0	0	0	0	0	0	1	1	+3	
0	0	0	0	0	0	1	0	+2	
0	0	0	0	0	0	0	1	+1	
0	0	0	0	0	0	0	0	0 (note 1)	
0	0	0	1	1	1	1	1	-1	
0	0	0	1	1	1	1	0	-2	
0	0	0	1	1	1	0	1	-3	
0	0	0	1	1	1	0	0	-4	
0	0	0	1	1	0	1	1	-5	
0	0	0	1	1	0	1	0	-6	
0	0	0	1	1	0	0	1	-7	
0	0	0	1	1	0	0	0	-8	
0	0	0	1	0	1	1	1	-9	
0	0	0	1	0	1	1	0	-10	
0	0	0	1	0	1	0	1	-11	
0	0	0	1	0	1	0	0	-12	
0	0	0	1	0	0	1	1	-13	
0	0	0	1	0	0	1	0	-14	
0	0	0	1	0	0	0	1	-15	
0	0	0	1	0	0	0	0	mute	

## Note

1. The default setting at power-up is 00000000.

## Digital TV Sound Processor (DTVSP)

## TDA9870A

10.3.37 I<sup>2</sup>S2 OUTPUT LEVEL ADJUST REGISTER

## 10.3.37.1 Description

This register is used to adjust the output level at the I<sup>2</sup>S2 interface. Left and right signal channel are treated identically.

## 10.3.37.2 Definition

Table 83 Subaddress 42

MSB							LSB		GAIN SETTING (dB)
B7	B6	B5	B4	B3	B2	B1	B0		
0	0	0	0	1	1	1	1	+15	
0	0	0	0	1	1	1	0	+14	
0	0	0	0	1	1	0	1	+13	
0	0	0	0	1	1	0	0	+12	
0	0	0	0	1	0	1	1	+11	
0	0	0	0	1	0	1	0	+10	
0	0	0	0	1	0	0	1	+9	
0	0	0	0	1	0	0	0	+8	
0	0	0	0	0	1	1	1	+7	
0	0	0	0	0	1	1	0	+6	
0	0	0	0	0	1	0	1	+5	
0	0	0	0	0	1	0	0	+4	
0	0	0	0	0	0	1	1	+3	
0	0	0	0	0	0	1	0	+2	
0	0	0	0	0	0	0	1	+1	
0	0	0	0	0	0	0	0	0 (note 1)	
0	0	0	1	1	1	1	1	-1	
0	0	0	1	1	1	1	0	-2	
0	0	0	1	1	1	0	1	-3	
0	0	0	1	1	1	0	0	-4	
0	0	0	1	1	0	1	1	-5	
0	0	0	1	1	0	1	0	-6	
0	0	0	1	1	0	0	1	-7	
0	0	0	1	1	0	0	0	-8	
0	0	0	1	0	1	1	1	-9	
0	0	0	1	0	1	1	0	-10	
0	0	0	1	0	1	0	1	-11	
0	0	0	1	0	1	0	0	-12	
0	0	0	1	0	0	1	1	-13	
0	0	0	1	0	0	1	0	-14	
0	0	0	1	0	0	0	1	-15	
0	0	0	1	0	0	0	0	mute	

## Note

1. The default setting at power-up is 00000000.

## Digital TV Sound Processor (DTVSP)

## TDA9870A

## 10.3.38 BEEPER FREQUENCY CONTROL REGISTER

## 10.3.38.1 Description

This register is used to select from sample beeper oscillator frequencies. The beeper output signal is added to the Main and Auxiliary channel output DAC.

Due to the frequency response of the audio DACs upsampling filters, the 25 kHz beep is approximately 5 dB louder than the 390 Hz beep.

## 10.3.38.2 Definition

Table 84 Subaddress 43 (note 1)

MSB							LSB		GENERATED FREQUENCY (Hz)
B7	B6	B5	B4	B3	B2	B1	B0		
0	0	0	0	0	1	1	1	25000	
0	0	0	0	0	1	1	0	7040	
0	0	0	0	0	1	0	1	3580	
0	0	0	0	0	1	0	0	1770	
0	0	0	0	0	0	1	1	1270	
0	0	0	0	0	0	1	0	900	
0	0	0	0	0	0	0	1	640	
0	0	0	0	0	0	0	0	390	

## Note

1. The default setting at power-up is 00000000.

## 10.3.39 BEEPER VOLUME CONTROL REGISTER

## 10.3.39.1 Description

This register is used to set the beeper volume. The gain setting is relative to digital full scale at the input to the Main and Auxiliary channel output DACs. The beeper volume is independent of any other volume setting.

The beeper signal is added to the Main and Auxiliary channel output signals in the  $2 \times f_s$  domain. The beeper volume should be set with great care, when the audio signals in the Main and Auxiliary channels are close to digital full-scale, to avoid output signal distortion due to overload.

## Digital TV Sound Processor (DTVSP)

## TDA9870A

## 10.3.39.2 Definition

Table 85 Subaddress 44

MSB							LSB	GAIN SETTING (dB)
B7	B6	B5	B4	B3	B2	B1	B0	
0	0	0	0	0	0	0	0	0
0	0	1	1	1	1	1	1	-3
0	0	1	1	1	1	1	0	-6
0	0	1	1	1	1	0	1	-9
0	0	1	1	1	1	0	0	-12
0	0	1	1	1	0	1	1	-15
0	0	1	1	1	0	1	0	-18
0	0	1	1	1	0	0	1	-21
0	0	1	1	1	0	0	0	-24
0	0	1	1	0	1	1	1	-27
0	0	1	1	0	1	1	0	-30
0	0	1	1	0	1	0	1	-33
0	0	1	1	0	1	0	0	-36
0	0	1	1	0	0	1	1	-39
0	0	1	1	0	0	1	0	-42
0	0	1	1	0	0	0	1	-45
0	0	1	1	0	0	0	0	-48
0	0	1	0	1	1	1	1	-51
0	0	1	0	1	1	1	0	-54
0	0	1	0	1	1	0	1	-57
0	0	1	0	1	1	0	0	-60
0	0	1	0	1	0	1	1	-63
0	0	1	0	1	0	1	0	-66
0	0	1	0	1	0	0	1	-69
0	0	1	0	1	0	0	0	-72
0	0	1	0	0	1	1	1	-75
0	0	1	0	0	1	1	0	-78
0	0	1	0	0	1	0	1	-81
0	0	1	0	0	1	0	0	-84
0	0	1	0	0	0	1	1	-87
0	0	1	0	0	0	1	0	-90
0	0	1	0	0	0	0	1	-93
0	0	1	0	0	0	0	0	mute (note 1)

**Note**

1. The default setting at power-up is 00100000.



# Digital TV Sound Processor (DTVSP)

# TDA9870A

## 10.3.40 BASS BOOST CONTROL REGISTER

### 10.3.40.1 Description

This register is used to select from a few sample bass boost settings to modify the frequency characteristics of the Main channel (shelving filter). Bits B3 to B0 apply to the left channel, bits B7 to B4 apply to the right channel. This function must be used with care in order to avoid clipping distortion at high volume settings.

More sophisticated control of the bass boost filter can be exercised in the expert mode (see Section 10.5). The user then has full control over this 2nd-order filter and can, within limits, realize bass equalizers with arbitrary centre frequencies, Q factors and boost/cut settings.

### 10.3.40.2 Definition

**Table 86** Subaddress 45 (note 1; see Table 87)

MSB				LSB			
B7	B6	B5	B4	B3	B2	B1	B0

**Note**

1. The default setting at power-up is 00000000.

**Table 87** Gain setting

B7 AND B3	B6 AND B2	B5 AND B1	B4 AND B0	GAIN SETTING (dB)	CORNER FREQUENCY (Hz)
1	0	1	0	20	350
1	0	0	1	18	350
1	0	0	0	16	350
0	1	1	1	14	350
0	1	1	0	12	350
0	1	0	1	10	350
0	1	0	0	8	350
0	0	1	1	6	350
0	0	1	0	4	350
0	0	0	1	2	350
0	0	0	0	0	350

## Digital TV Sound Processor (DTVSP)

## TDA9870A

**10.4 Slave transmitter mode**

As a slave transmitter, the TDA9870A provides 13 registers with status information and data, a part of which is for Philips internal purposes only. These registers can be accessed by means of subaddresses.

**Table 88** General format for reading data from the TDA9870A

S	SLAVE ADDRESS	0	ACK	SUBADDRESS	ACK	Sr	SLAVE ADDRESS	1	ACK	DATA	NAm	P
---	---------------	---	-----	------------	-----	----	---------------	---	-----	------	-----	---

**Table 89** Explanation of Tables 88 and 90

BIT	FUNCTION
S	START condition
SLAVE ADDRESS	7-bit device address
0	data direction bit (write to device)
ACK	acknowledge (by the slave)
SUBADDRESS	address of register to read from
Sr	repeated START condition
1	data direction bit (read from device)
DATA	data byte read from register
NAm	not acknowledge (by the master)
Am	acknowledge (by the master)
P	STOP condition

Reading of data can start at any valid subaddress. It is allowed to read more than 1 data byte per transmission from the TDA9870A. In this situation, the subaddress is automatically incremented after each data byte, which results in reading the sequence of data bytes from successive register locations, starting at SUBADDRESS.

**Table 90** Format of a transmission using automatic incrementing of subaddresses

S	SLAVE ADDRESS	0	ACK	SUBADDRESS	ACK	Sr	SLAVE ADDRESS	1	ACK	DATA BYTE Am <sup>(1)</sup>	DATA	NAm	P
---	---------------	---	-----	------------	-----	----	---------------	---	-----	--------------------------------	------	-----	---

**Note**

1. n data bytes with auto-increment of subaddresses.

Each data byte in a read sequence, except for the last one, is acknowledged with Am (acknowledge by the master). The subaddresses 'wrap around' from decimal 255 to 0. If an attempt is made to read from a non-existing subaddress, the device will send a data pattern of all ones, i.e. FF in hexadecimal notation.

## Digital TV Sound Processor (DTVSP)

## TDA9870A

**Table 91** Overview of the slave transmitter registers (note 1)

SUBADDRESS (DECIMAL)	DATA								FUNCTION
	MSB				LSB				
0	s	s	X	X	X	s	s	s	device status (power-on, identification, etc.)
1	X	X	X	X	X	X	X	X	don't care; note 1
2	X	X	X	X	X	X	X	X	don't care; note 1
3	X	X	X	X	X	X	X	X	don't care; note 1
4	X	X	X	X	X	X	X	X	don't care; note 1
5	l	l	l	l	l	l	l	l	level read-out (MSB)
6	l	l	l	l	l	l	l	l	level read-out (LSB)
7	X	X	X	c	c	c	c	c	SIF level
251	a	a	a	a	a	a	a	a	test register 3; note 2
252	a	a	a	a	a	a	a	a	test register 2; note 2
253	a	a	a	a	a	a	a	a	test register 1; note 2
254	d	d	d	d	d	d	d	d	device identification code
255	s	s	s	s	s	s	s	s	software identification code

**Notes**

1. X indicates a bit that has not been assigned to a function. This bit is reserved for future extensions.
2. Registers from subaddress 251 to 255 are for Philips internal purposes only. They are considered as a set of registers for the identification of individual members and some key parameters in a family of devices.

A detailed description of the slave transmitter registers is given in below.

## 10.4.1 DEVICE STATUS REGISTER

## 10.4.1.1 Description

**Table 92** Description of Table 93

NAME	HIGH/LOW	FUNCTION
POR	–	The power supply for the digital part of the device, $V_{DD2}$ , has temporarily been lower than the specified lower limit. If this is detected an initialization of the TDA9870A has to be carried out to ensure reliable operation.
IDSTE	–	this bit is HIGH if an FM stereo signal has been identified
IDDUA	–	This bit is HIGH if an FM dual-language signal has been identified. When neither IDSTE nor IDDUA are set, the received signal has to be assumed to be FM mono.
P1IN, P2IN	–	these bits reflect the status of the corresponding general purpose port pins, see Section 10.3.2

Digital TV Sound Processor (DTVSP)

TDA9870A

10.4.1.2 Definition

**Table 93** Subaddress 0

BIT	NAME	DESCRIPTION
7 (MSB)	P2IN	input from port 2
6	P1IN	input from port 1
5	–	don't care
4	–	don't care
3	–	don't care
2	IDDUA	identification of FM dual sound
1	IDSTE	identification of FM stereo
0 (LSB)	POR	power fail bit

10.4.2 REGISTER 1

10.4.2.1 Description

Subaddress 1: These bits have not been assigned to a function. These bits are reserved for future extensions.

10.4.3 REGISTER 2

10.4.3.1 Description

Subaddress 2: These bits have not been assigned to a function. These bits are reserved for future extensions.

10.4.4 REGISTER 3

10.4.4.1 Description

Subaddress 3: These bits have not been assigned to a function. These bits are reserved for future extensions.

10.4.5 REGISTER 4

10.4.5.1 Description

Subaddress 4: These bits have not been assigned to a function. These bits are reserved for future extensions.

10.4.6 LEVEL READ-OUT REGISTERS

10.4.6.1 Description

These two bytes constitute a word that provides data from a location that has been specified with the monitor select register. The most significant byte of the data is stored at subaddress 5.

If peak-level monitoring has been selected, the peak-level monitoring register is cleared and monitoring resumes after its contents has been transferred to these two bytes.

10.4.6.2 Definition

**Table 94** Subaddress 5

BIT
7 (most significant bit or sign bit)
6
5
4
3
2
1
0

**Table 95** Subaddress 6

BIT
7
6
5
4
3
2
1
0 (least significant bit)

10.4.7 SIF LEVEL REGISTER

10.4.7.1 Description

When the SIF AGC is on, bits B4 to B0 of this register contain a number that gives an indication of the SIF input level. That number corresponds to the AGC gain register setting (see Section 10.3, subaddress 0).

## Digital TV Sound Processor (DTVSP)

## TDA9870A

When the SIF AGC is off, this register returns the contents of the AGC gain register.

#### 10.4.7.2 Definition

**Table 96** Subaddress 7

MSB							LSB
B7	B6	B5	B4	B3	B2	B1	B0

#### 10.4.8 TEST REGISTER 3

##### 10.4.8.1 Description

This register contains, as a binary number, the highest memory address used for the Coefficient RAM (CRAM, expert mode).

##### 10.4.8.2 Definition

**Table 97** Subaddress 251

MSB							LSB
B7	B6	B5	B4	B3	B2	B1	B0
0	1	1	1	1	1	1	1

#### 10.4.9 TEST REGISTER 2

##### 10.4.9.1 Description

This register contains, as a binary number, the highest subaddress used for slave receiver registers.

##### 10.4.9.2 Definition

**Table 98** Subaddress 252

MSB							LSB
B7	B6	B5	B4	B3	B2	B1	B0
0	0	1	0	1	1	0	1

#### 10.4.10 TEST REGISTER 1

##### 10.4.10.1 Description

This register contains, as a binary number, the highest subaddress used for slave transmitter (status) registers.

##### 10.4.10.2 Definition

**Table 99** Subaddress 253

MSB							LSB
B7	B6	B5	B4	B3	B2	B1	B0
0	0	0	0	0	1	1	1

#### 10.4.11 DEVICE IDENTIFICATION CODE

##### 10.4.11.1 Description

There will be several devices in the digital TV sound processor family. This byte is used to identify the individual family members.

##### 10.4.11.2 Definition

**Table 100** Subaddress 254

MSB							LSB
B7	B6	B5	B4	B3	B2	B1	B0
0	0	1	0	0	0	1	0

#### 10.4.12 SOFTWARE IDENTIFICATION CODE

##### 10.4.12.1 Description

It is likely that during the life time of this family of devices several versions of the DSP software will be made, e.g., to accommodate new application concepts, respond to customer wishes, etc. This byte is used to identify the different releases.

##### 10.4.12.2 Definition

**Table 101** Subaddress 255

MSB							LSB
B7	B6	B5	B4	B3	B2	B1	B0
0	0	0	0	0	0	1	0

### 10.5 Expert mode

In addition to the slave receiver and slave transmitter modes previously described, there is a special 'expert' mode that gives direct write access to the internal CRAM of the DSP.

In this mode, transferred data contain 12-bit-wide coefficients. As those coefficients bypass on-chip coefficient look-up tables for many functions, they directly influence the processing of signals within the DSP.

This mode must be used with great care. It can be used to create user-defined characteristics, such as a tone control with different corner frequencies or special boost/cut characteristics to correct the low-frequency loudspeaker and/or cabinet frequency responses.

## Digital TV Sound Processor (DTVSP)

## TDA9870A

**Table 102** General format for entering the expert mode and writing coefficients into the TDA9870A

S	SLAVE ADDRESS	0	ACK	10000000	ACK	CRAM ADDRESS	ACK	DATA	ACK	DATA	ACK	P
---	---------------	---	-----	----------	-----	--------------	-----	------	-----	------	-----	---

**Table 103** Explanation of Table 102

BIT	FUNCTION
S	START condition
SLAVE ADDRESS	7-bit device address
0	data direction bit (write to device)
ACK	acknowledge
10000000	pattern to enter the expert mode
CRAM ADDRESS	start address of coefficient RAM to write to
DATA	data byte containing part of a coefficient
P	STOP condition

As the coefficients do not fit into one data byte, they have to be split and arranged (see Table 104). The most significant bit is transferred first.

**Table 104** General format (notes 1, 2 and 3)

BYTE	DATA								DESCRIPTION
1. data byte	a	a	a	a	a	a	a	a	2 MST of 1st coefficient
2. data byte	a	a	a	a	X	X	X	X	1 LST of 1st coefficient

**Notes**

1. X = don't care.
2. MST = most significant third.
3. LST = least significant third.

The general format described in Table 104 shows the minimum number of data bytes required, i.e. two bytes for the transfer of a single coefficient.

Should more than one coefficient be sent, then the CRAM address will be automatically incremented after each coefficient, resulting in writing the sequence of coefficients into successive memory locations, starting at CRAM ADDRESS. A transmission can start with any valid CRAM address. If two coefficients are to be transferred, they are arranged as shown in Table 105.

**Table 105** Transfer of two coefficients

BYTE	DATA								DESCRIPTION
1 data byte	a	a	a	a	a	a	a	a	2 MST of 1st coefficient
2 data byte	a	a	a	a	b	b	b	b	1 LST of 1st coefficient + 1 MST of 2nd coefficient
3 data byte	b	b	b	b	b	b	b	b	2 LST of 2nd coefficient

With any odd number of coefficients to be transferred, the least significant nibble of the last byte is regarded as containing don't care data.

## Digital TV Sound Processor (DTVSP)

## TDA9870A

As the transfer of coefficients cannot be accomplished within one audio sample period, it is necessary that received coefficients be buffered and made active all at the same time to avoid audio signal transients. The receive buffer is designed to store up to 8 coefficients in addition to the CRAM address. Each byte that fits into the buffer is acknowledged with ACK (acknowledge). If an attempt is made to write more coefficients than the buffer can store, the device acknowledges with NACK (not acknowledge) and any further coefficients are ignored. Coefficients that are already in the receive buffer remain intact.

An expert mode transfer ends when the I<sup>2</sup>C-bus STOP condition or a repeated START condition has been detected. Only those coefficients that have been received during the last transmission will then be copied from the buffer to the CRAM.

To make efficient and correct use of the expert mode, it is recommended to transfer all coefficients for any one function in a single transmission.

There is no checking of memory addresses and the automatic incrementing of addresses does not stop at the highest used CRAM address. The user of this expert mode must be fully acquainted with the relevant procedures.

More information concerning the functions of this device, such as the number of coefficients per function, their default values, memory addresses, etc., can be supplied on request at a later date.

### 11 I<sup>2</sup>S-BUS DESCRIPTION

The feature interface of the TDA9870A contains two serial audio inputs and outputs and associated clock signals. It can be used to supply, for example, audio signals from received TV programs to a digital audio output device (AES/EBU format), or import serial audio signals from other sources for reproduction through the TV set's loudspeaker and/or headphone channels. Apart from such simple data input or output, it is also possible to run audio signals through an external DSP, which performs some additional functions, such as room simulation, Dolby Surround Pro Logic etc. and feed those signals back into the loudspeaker and/or headphone channels of the TDA9870A.

Two serial audio formats are supported at the feature interface, i.e. the I<sup>2</sup>S-bus format and a very similar MSB-aligned format. The difference is illustrated in Fig.7.

In both formats the left audio channel of a stereo sample pair is output first and is placed on the serial data line (SDI for input, SDO for output) when the word select line (WS)

is LOW. Data is written at the trailing edge of SCK and read at the leading edge of SCK. The most significant bit is sent first.

At power-up, the outputs of the feature interface are 3-stated to reduce EMC and allow for combinations with other ICs. If output is desired, it has to be activated by means of an I<sup>2</sup>C-bus command.

When the output is enabled, the serial audio data can be taken from pins SDO1 and SDO2. Depending on the signal source, switch and matrix positions, the output can be either mono, stereo or dual language sound on either output.

The word select output is clocked with the audio sample frequency at 32 kHz. The serial clock output (SCK) is clocked at a frequency of 2.048 MHz. This means, that there are 64 clock pulses per pair of stereo output samples, or 32 clock pulses per sample. Depending again on the signal source, the number of significant bits on the serial data outputs, SDO1 and SDO2, is between 14 and 18.

Apart from just feeding a digital audio device, such as a DAC or an AES/EBU transmitter, the serial data outputs can be connected directly to the serial inputs (loop-back connection) or first to an external device, e.g. a feature DSP such as the SAA7710 and then back to the serial inputs. In all of these configurations, the SCK and WS clocks will be generated by the TDA9870A, which then is the I<sup>2</sup>S-bus master.

The serial data inputs, SDI1 and SDI2, are active at all times, independent of the serial data outputs being on or off. When the serial data outputs are off (either after power-up or via the appropriate I<sup>2</sup>C-bus command) serial data and clocks WS and SCK from a separate digital audio source can be fed into the TDA9870A, be processed and output in accordance with internal selector positions, provided that the following criteria are met:

- 32 kHz audio sample frequency
- 32 clock bits per sample
- External timing and data synchronized to TDA9870A.

In such cases, the external source is the I<sup>2</sup>S-bus master and the TDA9870A is the I<sup>2</sup>S-bus slave.

To support synchronization of external devices or as a master clock for them, a system clock output, SYSCLK, is available from the TDA9870A. At power-up it is off. It can be enabled and the output frequency set via an I<sup>2</sup>C-bus command. Available output frequencies are 8.192, 12.288, 16.384 and 24.576 MHz.

Digital TV Sound Processor (DTVSP)

TDA9870A

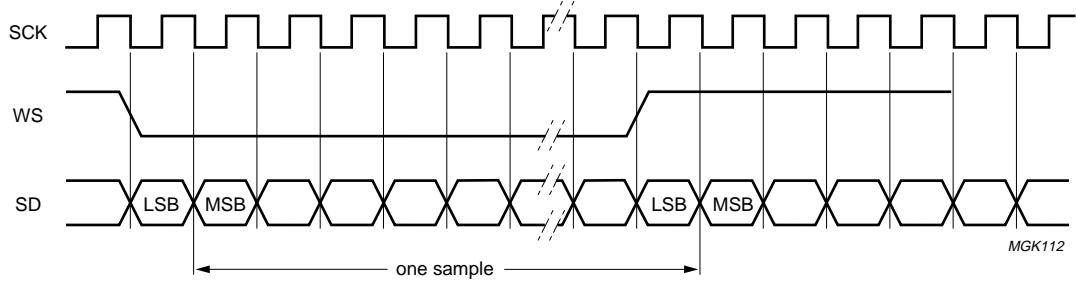

a. I<sup>2</sup>S-bus format.

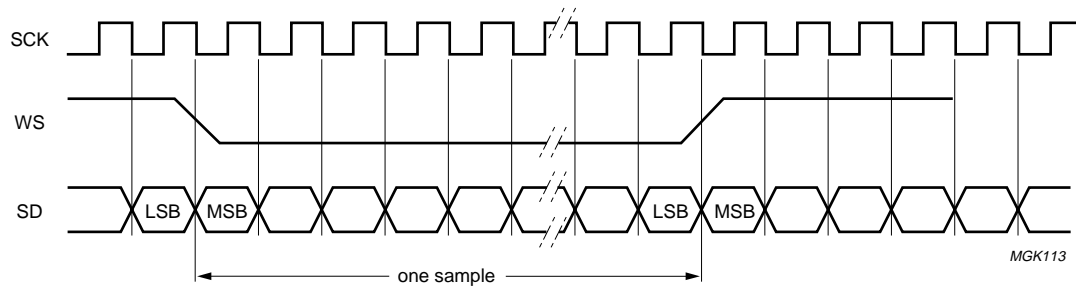

b. MSB-aligned format.

Fig.7 Serial audio interface formats.



Digital TV Sound Processor (DTVSP)

TDA9870A

12 EXTERNAL COMPONENTS

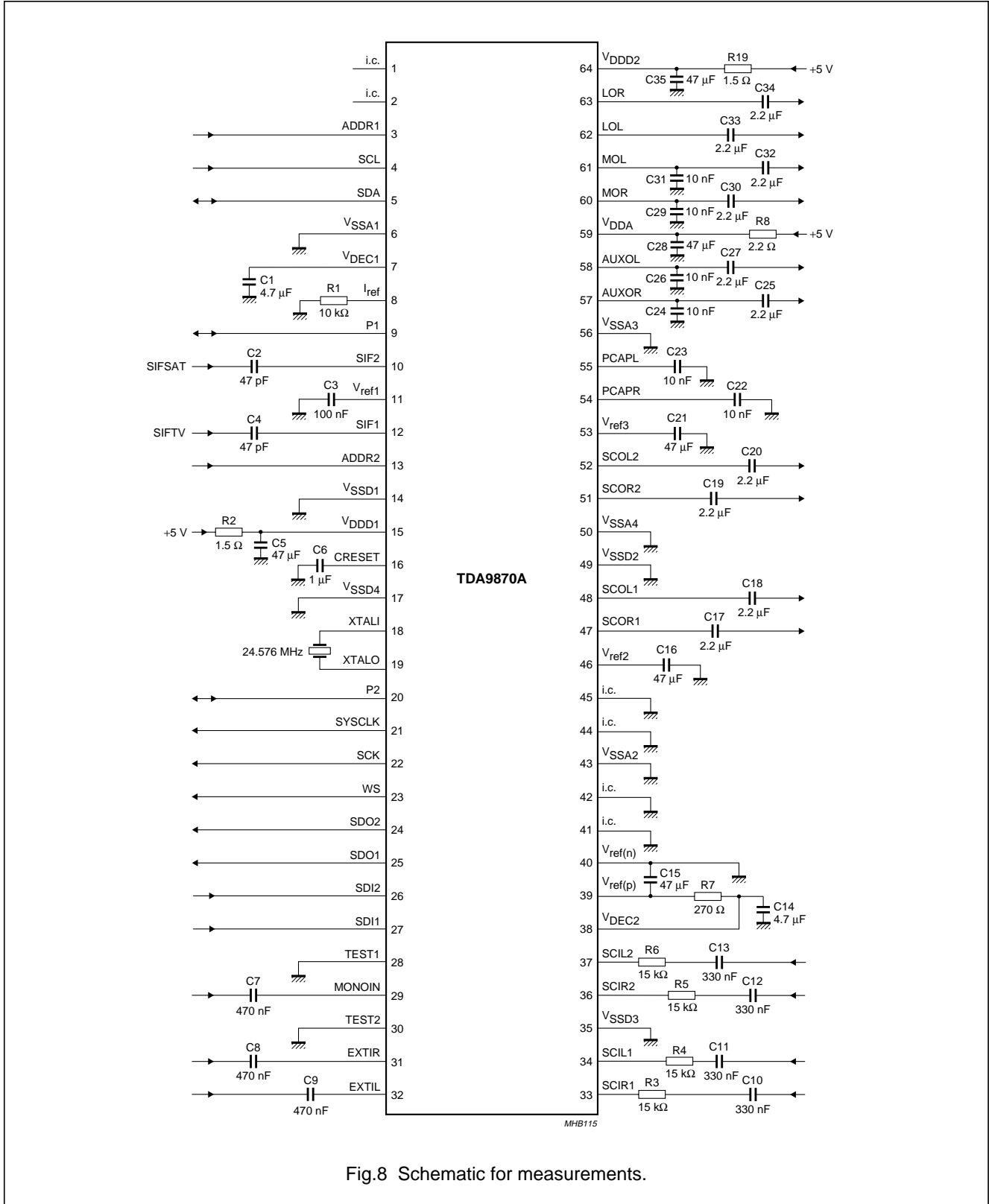

Fig.8 Schematic for measurements.

Digital TV Sound Processor (DTVSP)

TDA9870A

13 APPLICATION CIRCUITRY

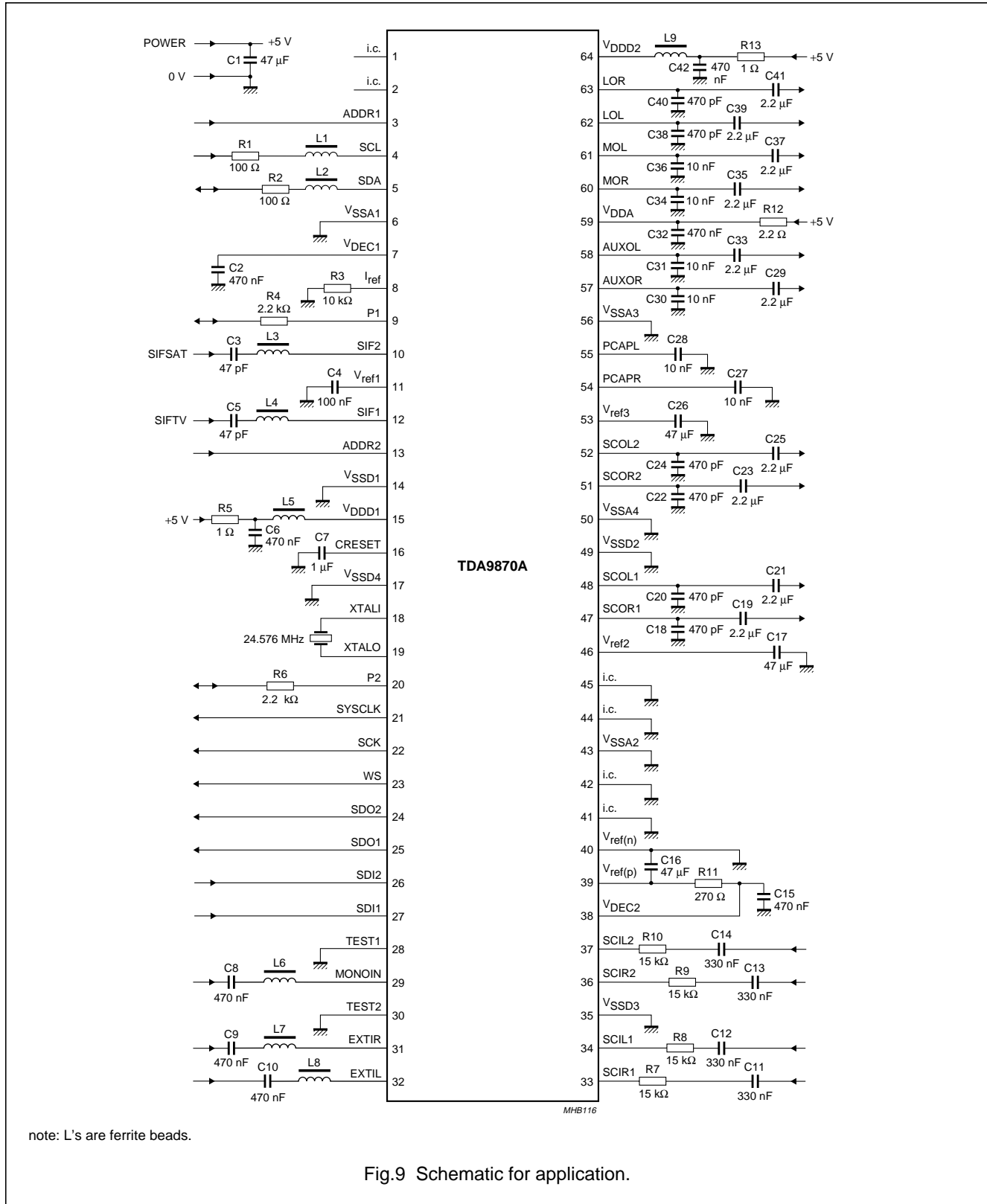

Fig.9 Schematic for application.

Digital TV Sound Processor (DTVSP)

TDA9870A

14 PACKAGE OUTLINE

SDIP64: plastic shrink dual in-line package; 64 leads (750 mil)

SOT274-1

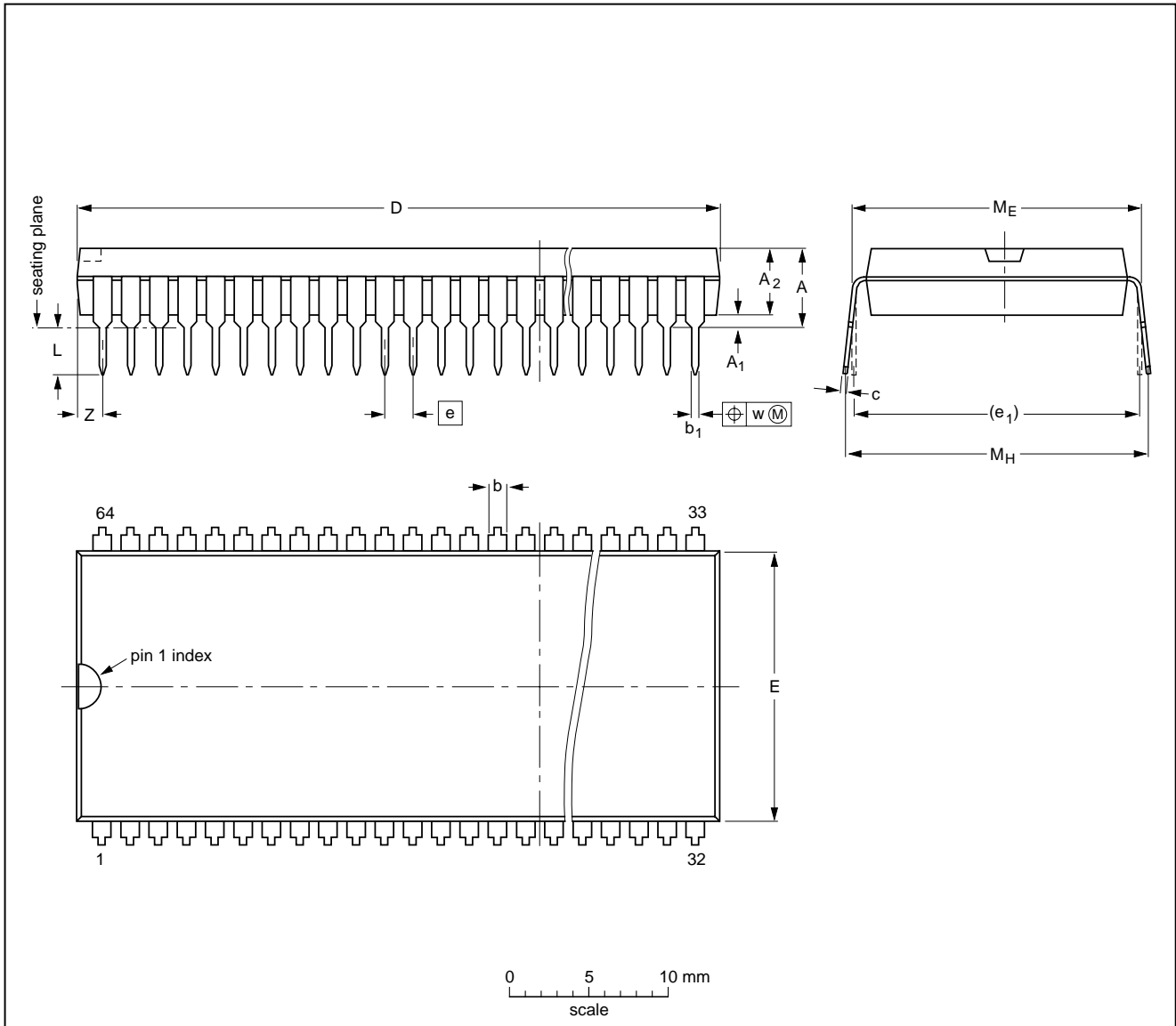

DIMENSIONS (mm are the original dimensions)

UNIT	A max.	A <sub>1</sub> min.	A <sub>2</sub> max.	b	b <sub>1</sub>	c	D <sup>(1)</sup>	E <sup>(1)</sup>	e	e <sub>1</sub>	L	M <sub>E</sub>	M <sub>H</sub>	w	z <sup>(1)</sup> max.
mm	5.84	0.51	4.57	1.3 0.8	0.53 0.40	0.32 0.23	58.67 57.70	17.2 16.9	1.778	19.05	3.2 2.8	19.61 19.05	20.96 19.71	0.18	1.73

Note

1. Plastic or metal protrusions of 0.25 mm maximum per side are not included.

OUTLINE VERSION	REFERENCES			EUROPEAN PROJECTION	ISSUE DATE
	IEC	JEDEC	EIAJ		
SOT274-1					92-10-13 95-02-04

## Digital TV Sound Processor (DTVSP)

TDA9870A

### 15 SOLDERING

#### 15.1 Introduction

There is no soldering method that is ideal for all IC packages. Wave soldering is often preferred when through-hole and surface mounted components are mixed on one printed-circuit board. However, wave soldering is not always suitable for surface mounted ICs, or for printed-circuits with high population densities. In these situations reflow soldering is often used.

This text gives a very brief insight to a complex technology. A more in-depth account of soldering ICs can be found in our "IC Package Databook" (order code 9398 652 90011).

#### 15.2 Soldering by dipping or by wave

The maximum permissible temperature of the solder is 260 °C; solder at this temperature must not be in contact with the joint for more than 5 seconds. The total contact

time of successive solder waves must not exceed 5 seconds.

The device may be mounted up to the seating plane, but the temperature of the plastic body must not exceed the specified maximum storage temperature ( $T_{stg\ max}$ ). If the printed-circuit board has been pre-heated, forced cooling may be necessary immediately after soldering to keep the temperature within the permissible limit.

#### 15.3 Repairing soldered joints

Apply a low voltage soldering iron (less than 24 V) to the lead(s) of the package, below the seating plane or not more than 2 mm above it. If the temperature of the soldering iron bit is less than 300 °C it may remain in contact for up to 10 seconds. If the bit temperature is between 300 and 400 °C, contact may be up to 5 seconds.

### 16 DEFINITIONS

<b>Data sheet status</b>	
Objective specification	This data sheet contains target or goal specifications for product development.
Preliminary specification	This data sheet contains preliminary data; supplementary data may be published later.
Product specification	This data sheet contains final product specifications.
<b>Limiting values</b>	
Limiting values given are in accordance with the Absolute Maximum Rating System (IEC 134). Stress above one or more of the limiting values may cause permanent damage to the device. These are stress ratings only and operation of the device at these or at any other conditions above those given in the Characteristics sections of the specification is not implied. Exposure to limiting values for extended periods may affect device reliability.	
<b>Application information</b>	
Where application information is given, it is advisory and does not form part of the specification.	

### 17 LIFE SUPPORT APPLICATIONS

These products are not designed for use in life support appliances, devices, or systems where malfunction of these products can reasonably be expected to result in personal injury. Philips customers using or selling these products for use in such applications do so at their own risk and agree to fully indemnify Philips for any damages resulting from such improper use or sale.

### 18 PURCHASE OF PHILIPS I<sup>2</sup>C COMPONENTS



Purchase of Philips I<sup>2</sup>C components conveys a license under the Philips' I<sup>2</sup>C patent to use the components in the I<sup>2</sup>C system provided the system conforms to the I<sup>2</sup>C specification defined by Philips. This specification can be ordered using the code 9398 393 40011.

Digital TV Sound Processor (DTVSP)

TDA9870A

---

**NOTES**

Digital TV Sound Processor (DTVSP)

TDA9870A

---

**NOTES**

Digital TV Sound Processor (DTVSP)

TDA9870A

---

**NOTES**

# Philips Semiconductors – a worldwide company

**Argentina:** see South America

**Australia:** 34 Waterloo Road, NORTH RYDE, NSW 2113, Tel. +61 2 9805 4455, Fax. +61 2 9805 4466

**Austria:** Computerstr. 6, A-1101 WIEN, P.O. Box 213, Tel. +43 160 1010, Fax. +43 160 101 1210

**Belarus:** Hotel Minsk Business Center, Bld. 3, r. 1211, Volodarski Str. 6, 220050 MINSK, Tel. +375 172 200 733, Fax. +375 172 200 773

**Belgium:** see The Netherlands

**Brazil:** see South America

**Bulgaria:** Philips Bulgaria Ltd., Energoproject, 15th floor, 51 James Bourchier Blvd., 1407 SOFIA, Tel. +359 2 689 211, Fax. +359 2 689 102

**Canada:** PHILIPS SEMICONDUCTORS/COMPONENTS, Tel. +1 800 234 7381

**China/Hong Kong:** 501 Hong Kong Industrial Technology Centre, 72 Tat Chee Avenue, Kowloon Tong, HONG KONG, Tel. +852 2319 7888, Fax. +852 2319 7700

**Colombia:** see South America

**Czech Republic:** see Austria

**Denmark:** Prags Boulevard 80, PB 1919, DK-2300 COPENHAGEN S, Tel. +45 32 88 2636, Fax. +45 31 57 0044

**Finland:** Sinikalliontie 3, FIN-02630 ESPOO, Tel. +358 9 615800, Fax. +358 9 61580920

**France:** 51 Rue Carnot, BP317, 92156 SURESNES Cedex, Tel. +33 1 40 99 6161, Fax. +33 1 40 99 6427

**Germany:** Hammerbrookstraße 69, D-20097 HAMBURG, Tel. +49 40 23 53 60, Fax. +49 40 23 536 300

**Greece:** No. 15, 25th March Street, GR 17778 TAVROS/ATHENS, Tel. +30 1 4894 339/239, Fax. +30 1 4814 240

**Hungary:** see Austria

**India:** Philips INDIA Ltd, Band Box Building, 2nd floor, 254-D, Dr. Annie Besant Road, Worli, MUMBAI 400 025, Tel. +91 22 493 8541, Fax. +91 22 493 0966

**Indonesia:** PT Philips Development Corporation, Semiconductors Division, Gedung Philips, Jl. Buncit Raya Kav.99-100, JAKARTA 12510, Tel. +62 21 794 0040 ext. 2501, Fax. +62 21 794 0080

**Ireland:** Newstead, Clonskeagh, DUBLIN 14, Tel. +353 1 7640 000, Fax. +353 1 7640 200

**Israel:** RAPAC Electronics, 7 Kehilat Saloniki St, PO Box 18053, TEL AVIV 61180, Tel. +972 3 645 0444, Fax. +972 3 649 1007

**Italy:** PHILIPS SEMICONDUCTORS, Piazza IV Novembre 3, 20124 MILANO, Tel. +39 2 6752 2531, Fax. +39 2 6752 2557

**Japan:** Philips Bldg 13-37, Kohnan 2-chome, Minato-ku, TOKYO 108-8507, Tel. +81 3 3740 5130, Fax. +81 3 3740 5077

**Korea:** Philips House, 260-199 Itaewon-dong, Yongsan-ku, SEOUL, Tel. +82 2 709 1412, Fax. +82 2 709 1415

**Malaysia:** No. 76 Jalan Universiti, 46200 PETALING JAYA, SELANGOR, Tel. +60 3 750 5214, Fax. +60 3 757 4880

**Mexico:** 5900 Gateway East, Suite 200, EL PASO, TEXAS 79905, Tel. +9-5 800 234 7381

**Middle East:** see Italy

**Netherlands:** Postbus 90050, 5600 PB EINDHOVEN, Bldg. VB, Tel. +31 40 27 82785, Fax. +31 40 27 88399

**New Zealand:** 2 Wagener Place, C.P.O. Box 1041, AUCKLAND, Tel. +64 9 849 4160, Fax. +64 9 849 7811

**Norway:** Box 1, Manglerud 0612, OSLO, Tel. +47 22 74 8000, Fax. +47 22 74 8341

**Pakistan:** see Singapore

**Philippines:** Philips Semiconductors Philippines Inc., 106 Valero St. Salcedo Village, P.O. Box 2108 MCC, MAKATI, Metro MANILA, Tel. +63 2 816 6380, Fax. +63 2 817 3474

**Poland:** Ul. Lukiska 10, PL 04-123 WARSZAWA, Tel. +48 22 612 2831, Fax. +48 22 612 2327

**Portugal:** see Spain

**Romania:** see Italy

**Russia:** Philips Russia, Ul. Usatcheva 35A, 119048 MOSCOW, Tel. +7 095 755 6918, Fax. +7 095 755 6919

**Singapore:** Lorong 1, Toa Payoh, SINGAPORE 319762, Tel. +65 350 2538, Fax. +65 251 6500

**Slovakia:** see Austria

**Slovenia:** see Italy

**South Africa:** S.A. PHILIPS Pty Ltd., 195-215 Main Road Martindale, 2092 JOHANNESBURG, P.O. Box 7430 Johannesburg 2000, Tel. +27 11 470 5911, Fax. +27 11 470 5494

**South America:** Al. Vicente Pinzon, 173, 6th floor, 04547-130 SÃO PAULO, SP, Brazil, Tel. +55 11 821 2333, Fax. +55 11 821 2382

**Spain:** Balmes 22, 08007 BARCELONA, Tel. +34 93 301 6312, Fax. +34 93 301 4107

**Sweden:** Kottbygatan 7, Akalla, S-16485 STOCKHOLM, Tel. +46 8 5985 2000, Fax. +46 8 5985 2745

**Switzerland:** Allmendstrasse 140, CH-8027 ZÜRICH, Tel. +41 1 488 2741 Fax. +41 1 488 3263

**Taiwan:** Philips Semiconductors, 6F, No. 96, Chien Kuo N. Rd., Sec. 1, TAIPEI, Taiwan Tel. +886 2 2134 2865, Fax. +886 2 2134 2874

**Thailand:** PHILIPS ELECTRONICS (THAILAND) Ltd., 209/2 Sanpavuth-Bangna Road Prakanong, BANGKOK 10260, Tel. +66 2 745 4090, Fax. +66 2 398 0793

**Turkey:** Talatpasa Cad. No. 5, 80640 GÜLTEPE/ISTANBUL, Tel. +90 212 279 2770, Fax. +90 212 282 6707

**Ukraine:** PHILIPS UKRAINE, 4 Patrice Lumumba str., Building B, Floor 7, 252042 KIEV, Tel. +380 44 264 2776, Fax. +380 44 268 0461

**United Kingdom:** Philips Semiconductors Ltd., 276 Bath Road, Hayes, MIDDLESEX UB3 5BX, Tel. +44 181 730 5000, Fax. +44 181 754 8421

**United States:** 811 East Arques Avenue, SUNNYVALE, CA 94088-3409, Tel. +1 800 234 7381

**Uruguay:** see South America

**Vietnam:** see Singapore

**Yugoslavia:** PHILIPS, Trg N. Pasica 5/v, 11000 BEOGRAD, Tel. +381 11 625 344, Fax. +381 11 635 777

**For all other countries apply to:** Philips Semiconductors, International Marketing & Sales Communications, Building BE-p, P.O. Box 218, 5600 MD EINDHOVEN, The Netherlands, Fax. +31 40 27 24825

**Internet:** <http://www.semiconductors.philips.com>

© Philips Electronics N.V. 1998

SCA60

All rights are reserved. Reproduction in whole or in part is prohibited without the prior written consent of the copyright owner.

The information presented in this document does not form part of any quotation or contract, is believed to be accurate and reliable and may be changed without notice. No liability will be accepted by the publisher for any consequence of its use. Publication thereof does not convey nor imply any license under patent- or other industrial or intellectual property rights.

Printed in The Netherlands

545104/1200/01/pp88

Date of release: 1998 Aug 10

Document order number: 9397 750 03839

*Let's make things better.*

**Philips  
Semiconductors**



**PHILIPS**